

# ***SYLVANIA*** **SERVICE MANUAL**

**27" COLOR TELEVISION  
6427TE/SST4274**

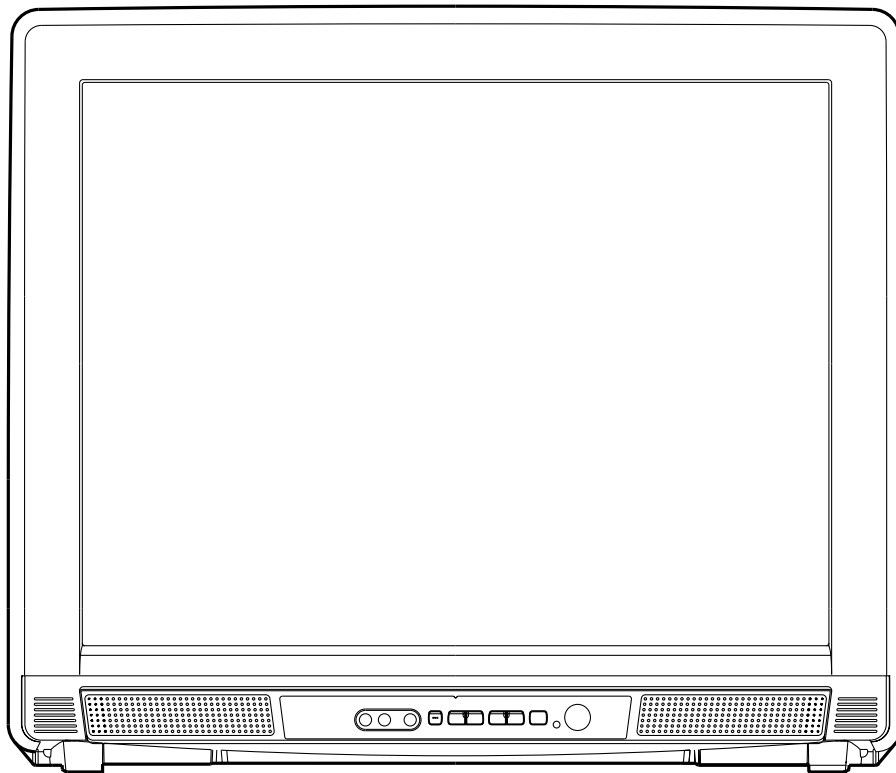

# IMPORTANT SAFETY NOTICE

Proper service and repair is important to the safe, reliable operation of all Funai Equipment. The service procedures recommended by Funai and described in this service manual are effective methods of performing service operations. Some of these service special tools should be used when and as recommended.

It is important to note that this service manual contains various CAUTIONS and NOTICES which should be carefully read in order to minimize the risk of personal injury to service personnel. The possibility exists that improper service methods may damage the equipment. It also is important to understand that these CAUTIONS and NOTICES ARE NOT EXHAUSTIVE. Funai could not possibly know, evaluate and advise the service trade of all conceivable ways in which service might be done or of the possible hazardous consequences of each way. Consequently, Funai has not undertaken any such broad evaluation. Accordingly, a servicer who uses a service procedure or tool which is not recommended by Funai must first use all precautions thoroughly so that neither his safety nor the safe operation of the equipment will be jeopardized by the service method selected.

## TABLE OF CONTENTS

Specifications .....	1-1	CBA Views and Test Points.....	7-11
Important Safety Precautions.....	2-1	Waveforms .....	8-1
Standard Notes for Servicing .....	3-1	Wiring Diagram.....	9-1
Cabinet Disassembly Instructions .....	4-1	IC Pin Functions .....	10-1
Electrical Adjustment Instructions .....	5-1	Cabinet Exploded Views.....	11-1
Block Diagrams .....	6-1	Packing Exploded Views .....	11-3
Schematic Diagrams / CBA's and Test Points .....	7-1	Mechanical Parts List .....	12-1
Schematic Diagrams .....	7-3	Electrical Parts List.....	13-1

# SPECIFICATIONS

## <TUNER>

ANT. Input ----- 75ohm Unbal., F type  
 Reference Level ----- 20Vp-p (CRT Green Cathode)  
 Test Input Signal ----- 400Hz 30% modulation

Description	Condition	Unit	Nominal	Limit
1. Intermediate Freq.	Picture	MHz	45.75	—
	Sound	MHz	41.25	—
2. Peak Picture Sens	VHF	dB $\mu$ v	15	30
	CATV	dB $\mu$ v	15	30
	UHF	dB $\mu$ v	15	40
3. AFT Pull In Range (10mV input)	—	MHz	$\pm$ 2.0	$\pm$ 0.7

## <DEFLECTION>

Description	Condition	Unit	Nominal	Limit
1. Deflection Freq.	Horizontal	KHz	15.734	—
	Vertical	Hz	60	—
2. Linearity	Horizontal	%	—	$\pm$ 15
	Vertical	%	—	$\pm$ 10
3. Over Scan	—	%	10	—
4. High Voltage	—	KV	29	—

## <VIDEO & CHROMA>

Description	Condition	Unit	Nominal	Limit
1. Misconvergence	Center	mm	—	0.4
	Side	mm	—	1.5
	Corner	mm	—	2.1
2. Brightness	APL 100%	Ft-L	25	15
3. Color Temperature	—	$^{\circ}$ K	9200 $^{\circ}$ K	—
4. Resolution	Horizontal	Line	250	—
	Vertical	Line	300	—

## <AUDIO>

All items are measured across 8 $\Omega$  load at speaker output terminal.

Description	Condition	Unit	Nominal	Limit
1. Audio Output Power	10% THD	W	1	0.8
2. Audio Distortion (w/LPF)	500mW	%	2	7
3. Audio Freq. Response	-3dB	Hz	70~11K	—

### Note:

Nominal specifications represent the design specifications. All units should be able to approximate these. Some will exceed and some may drop slightly below these specifications. Limit specifications represent the absolute worst condition that still might be considered acceptable. In no case should a unit fail to meet limit specifications.

# IMPORTANT SAFETY PRECAUTIONS

Prior to shipment from the factory, our products are strictly inspected for recognized product safety and electrical codes of the countries in which they are to be sold. However, in order to maintain such compliance, it is equally important to implement the following precautions when a set is being serviced.

## Safety Precautions for TV Circuit

1. **Before returning an instrument to the customer**, always make a safety check of the entire instrument, including, but not limited to, the following items:
  - a. Be sure that no built-in protective devices are defective and have been defeated during servicing. (1) Protective shields are provided on this chassis to protect both the technician and the customer. Correctly replace all missing protective shields, including any removed for servicing convenience. (2) When reinstalling the chassis and/or other assembly in the cabinet, be sure to put back in place all protective devices, including but not limited to, nonmetallic control knobs, insulating fishpapers, adjustment and compartment covers/shields, and isolation resistor/capacitor networks. **Do not operate this instrument or permit it to be operated without all protective devices correctly installed and functioning. Servicers who defeat safety features or fail to perform safety checks may be liable for any resulting damage.**
  - b. Be sure that there are no cabinet openings through which an adult or child might be able to insert their fingers and contact a hazardous voltage. Such openings include, but are not limited to, (1) spacing between the picture tube and the cabinet mask, (2) excessively wide cabinet ventilation slots, and (3) an improperly fitted and/or incorrectly secured cabinet back cover.
  - c. **Antenna Cold Check** - With the instrument AC plug removed from any AC source, connect an electrical jumper across the two AC plug prongs. Place the instrument AC switch in the on position. Connect one lead of an ohmmeter to the AC plug prongs tied together and touch the other ohmmeter lead in turn to each tuner antenna input exposed terminal screw and, if applicable, to the coaxial connector. If the measured resistance is less than 1.0 megohm or greater than 5.2 megohm, an abnormality exists that must be corrected before the instrument is returned to the customer. Repeat this test with the instrument AC switch in the off position.
  - d. **Leakage Current Hot Check** - With the instrument completely reassembled, plug the AC line cord directly into a 120V AC outlet. (Do not use an isolation transformer during this test.) Use a leak-

age current tester or a metering system that complies with American National Standards Institute (ANSI) C101.1 Leakage Current for Appliances and Underwriters Laboratories (UL) 1410, (50.7). With the instrument AC switch first in the on position and then in the off position, measure from a known earth ground (metal water pipe, conduit, etc.) to all exposed metal parts of the instrument (antennas, handle brackets, metal cabinet, screw heads, metallic overlays, control shafts, etc.), especially any exposed metal parts that offer an electrical return path to the chassis. Any current measured must not exceed 0.5 milli-ampere. Reverse the instrument power cord plug in the outlet and repeat the test.

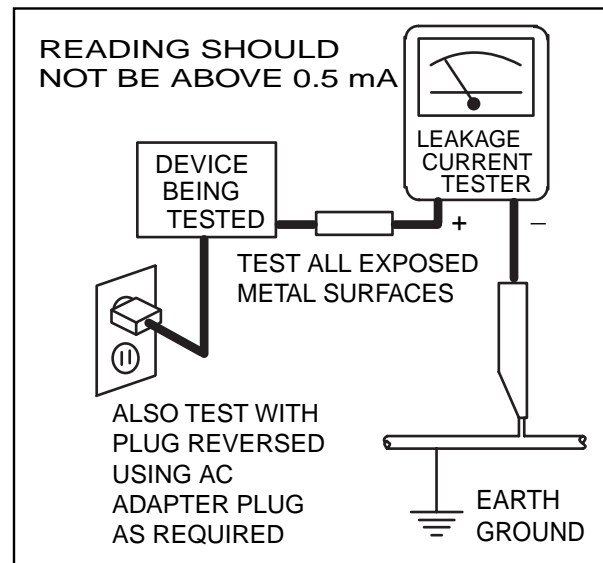

**ANY MEASUREMENTS NOT WITHIN THE LIMITS SPECIFIED HEREIN INDICATE A POTENTIAL SHOCK HAZARD THAT MUST BE ELIMINATED BEFORE RETURNING THE INSTRUMENT TO THE CUSTOMER OR BEFORE CONNECTING THE ANTENNA OR ACCESSORIES.**

- e. **X-Radiation and High Voltage Limits** - Because the picture tube is the primary potential source of X-radiation in solid-state TV receivers, it is specially constructed to prohibit X-radiation emissions. For continued X-radiation protection, the replacement picture tube must be the same type as the original. Also, because the picture tube shields and mounting hardware perform an X-radiation protection function, they must be correctly in place. High voltage must be measured each time servic-

ing is performed that involves B+, horizontal deflection or high voltage. Correct operation of the X-radiation protection circuits also must be reconfirmed each time they are serviced. (X-radiation protection circuits also may be called "horizontal disable" or "hold down.") Read and apply the high voltage limits and, if the chassis is so equipped, the X-radiation protection circuit specifications given on instrument labels and in the Product Safety & X-Radiation Warning note on the service data chassis schematic. High voltage is maintained within specified limits by close tolerance safety-related components/adjustments in the high-voltage circuit. If high voltage exceeds specified limits, check each component specified on the chassis schematic and take corrective action.

2. Read and comply with all caution and safety-related notes on or inside the receiver cabinet, on the receiver chassis, or on the picture tube.

3. **Design Alteration Warning** - Do not alter or add to the mechanical or electrical design of this TV receiver. Design alterations and additions, including, but not limited to circuit modifications and the addition of items such as auxiliary audio and/or video output connections, might alter the safety characteristics of this receiver and create a hazard to the user. Any design alterations or additions will void the manufacturer's warranty and may make you, the servicer, responsible for personal injury or property damage resulting therefrom.

4. **Picture Tube Implosion Protection Warning** - The picture tube in this receiver employs integral implosion protection. For continued implosion protection, replace the picture tube only with one of the same type number. Do not remove, install, or otherwise handle the picture tube in any manner without first putting on shatterproof goggles equipped with side shields. People not so equipped must be kept safely away while picture tubes are handled. Keep the picture tube away from your body. Do not handle the picture tube by its neck. Some "in-line" picture tubes are equipped with a permanently attached deflection yoke; because of potential hazard, do not try to remove such "permanently attached" yokes from the picture tube.

5. **Hot Chassis Warning** -

a. Some TV receiver chassis are electrically connected directly to one conductor of the AC power cord and maybe safety-serviced without an isolation transformer only if the AC power plug is inserted so that the chassis is connected to the ground side of the AC power source. To confirm that the AC power plug is inserted correctly, with an AC voltmeter, measure between the chassis and a known

earth ground. If a voltage reading in excess of 1.0V is obtained, remove and reinsert the AC power plug in the opposite polarity and again measure the voltage potential between the chassis and a known earth ground.

b. Some TV receiver chassis normally have 85V AC(RMS) between chassis and earth ground regardless of the AC plug polarity. This chassis can be safety-serviced only with an isolation transformer inserted in the power line between the receiver and the AC power source, for both personnel and test equipment protection.

c. Some TV receiver chassis have a secondary ground system in addition to the main chassis ground. This secondary ground system is not isolated from the AC power line. The two ground systems are electrically separated by insulation material that must not be defeated or altered.

6. Observe original lead dress. Take extra care to assure correct lead dress in the following areas:a. near sharp edges,b. near thermally hot parts-be sure that leads and components do not touch thermally hot parts,c. the AC supply,d. high voltage, and,e. antenna wiring. Always inspect in all areas for pinched, out of place, or frayed wiring. Check AC power cord for damage.

7. Components, parts, and/or wiring that appear to have overheated or are otherwise damaged should be replaced with components, parts, or wiring that meet original specifications. Additionally, determine the cause of overheating and/or damage and, if necessary, take corrective action to remove any potential safety hazard.

8. **Product Safety Notice** - Some electrical and mechanical parts have special safety-related characteristics which are often not evident from visual inspection, nor can the protection they give necessarily be obtained by replacing them with components rated for higher voltage, wattage, etc.. Parts that have special safety characteristics are identified by a (▲) on schematics and in parts lists. Use of a substitute replacement that does not have the same safety characteristics as the recommended replacement part might create shock, fire, and/or other hazards. The product's safety is under review continuously and new instructions are issued whenever appropriate. Prior to shipment from the factory, our products are strictly inspected to confirm they comply with the recognized product safety and electrical codes of the countries in which they are to be sold. However, in order to maintain such compliance, it is equally important to implement the following precautions when a set is being serviced.

## Precautions during Servicing

**A.** Parts identified by the (  ) symbol are critical for safety.

Replace only with part number specified.

**B.** In addition to safety, other parts and assemblies are specified for conformance with regulations applying to spurious radiation. These must also be replaced only with specified replacements.

Examples: RF converters, RF cables, noise blocking capacitors, and noise blocking filters, etc.

**C.** Use specified internal wiring. Note especially:

- 1) Wires covered with PVC tubing
- 2) Double insulated wires
- 3) High voltage leads

**D.** Use specified insulating materials for hazardous live parts. Note especially:

- 1) Insulation Tape
- 2) PVC tubing
- 3) Spacers
- 4) Insulators for transistors.

**E.** When replacing AC primary side components (transformers, power cord, etc.), wrap ends of wires securely about the terminals before soldering.

**F.** Observe that the wires do not contact heat producing parts (heatsinks, oxide metal film resistors, fusible resistors, etc.)

**G.** Check that replaced wires do not contact sharp edged or pointed parts.

**H.** When a power cord has been replaced, check that 5~6 kg of force in any direction will not loosen it.

**I.** Also check areas surrounding repaired locations.

**J.** Use care that foreign objects (screws, solder droplets, etc.) do not remain inside the set.

**K.** Crimp type wire connector

The power transformer uses crimp type connectors which connect the power cord and the primary side of the transformer. When replacing the transformer, follow these steps carefully and precisely to prevent shock hazards.

Replacement procedure

1) Remove the old connector by cutting the wires at a point close to the connector.

Important: Do not re-use a connector (discard it).

2) Strip about 15 mm of the insulation from the ends of the wires. If the wires are stranded, twist the strands to avoid frayed conductors.

3) Align the lengths of the wires to be connected. Insert the wires fully into the connector.

4) Use the crimping tool to crimp the metal sleeve at the center position. Be sure to crimp fully to the complete closure of the tool.

**L.** When connecting or disconnecting the internal connectors, first, disconnect the AC plug from the AC supply outlet.

## Safety Check after Servicing

Examine the area surrounding the repaired location for damage or deterioration. Observe that screws, parts and wires have been returned to original positions. Afterwards, perform the following tests and confirm the specified values in order to verify compliance with safety standards.

### 1. Clearance Distance

When replacing primary circuit components, confirm specified clearance distance ( $d$ ) and ( $d'$ ) between soldered terminals, and between terminals and surrounding metallic parts. (See Fig. 1)

**Table 1 : Ratings for selected area**

AC Line Voltage	Region	Clearance Distance ( $d$ ) ( $d'$ )
110 to 130 V	USA or CANADA	$\geq 3.2$ mm (0.126 inches)

**Note:** This table is unofficial and for reference only. Be sure to confirm the precise values.

### 2. Leakage Current Test

Confirm the specified (or lower) leakage current between B (earth ground, power cord plug prongs) and externally exposed accessible parts (RF terminals, antenna terminals, video and audio input and output terminals, microphone jacks, earphone jacks, etc.) is lower than or equal to the specified value in the table below.

#### Measuring Method : (Power ON)

Insert load  $Z$  between B (earth ground, power cord plug prongs) and exposed accessible parts. Use an AC voltmeter to measure across both terminals of load  $Z$ . See Fig. 2 and following table.

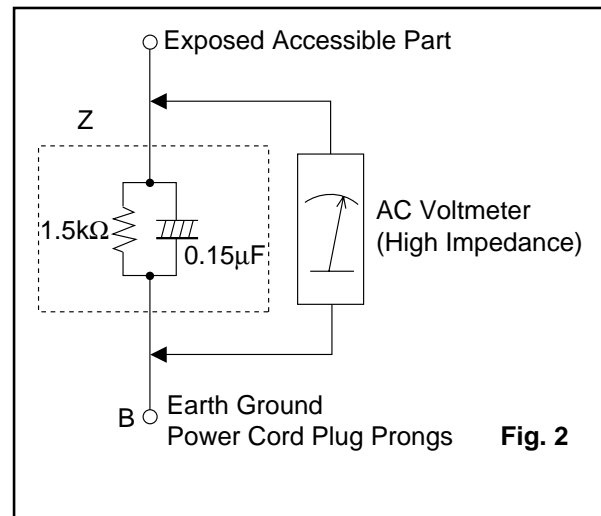
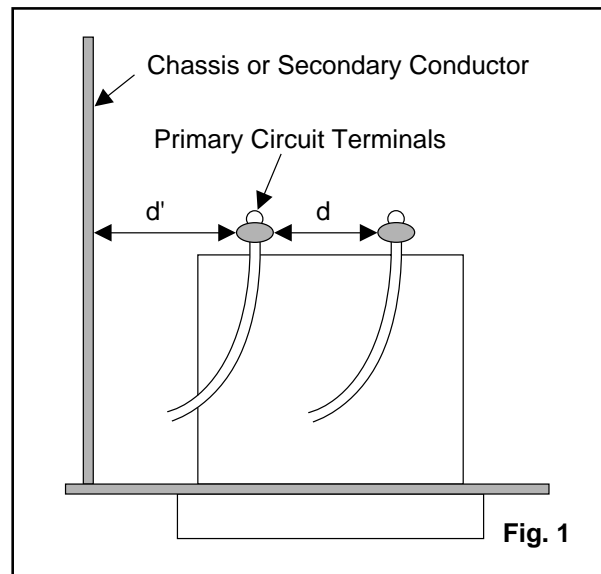

**Table 2 : Leakage current ratings for selected areas**

AC Line Voltage	Region	Load Z	Leakage Current ( $i$ )	Earth Ground (B) to:
110 to 130 V	USA	0.15 $\mu$ F CAP. & 1.5k $\Omega$ RES. connected in parallel	$i \leq 0.5$ mA rms	Exposed accessible parts

**Note:** This table is unofficial and for reference only. Be sure to confirm the precise values.

# STANDARD NOTES FOR SERVICING

## Circuit Board Indications

- a. The output pin of the 3 pin Regulator ICs is indicated as shown.

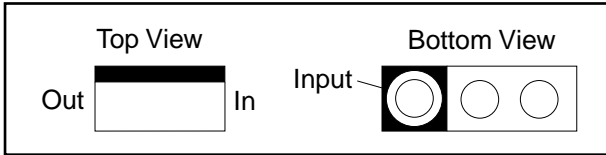

- b. For other ICs, pin 1 and every fifth pin are indicated as shown.

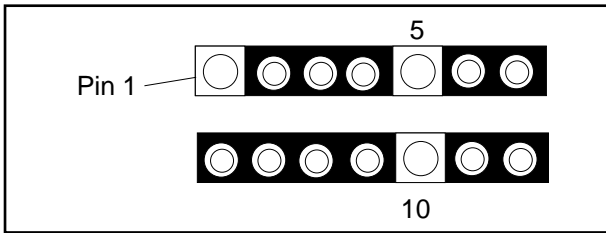

- c. The 1st pin of every male connector is indicated as shown.

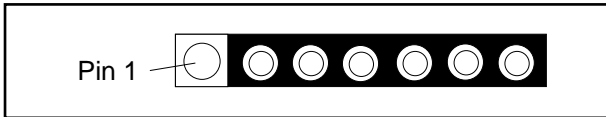

## Pb (Lead) Free Solder

**Pb free mark will be found on PCBs used Pb free solder. (Refer to figure.) For PCBs with Pb free mark, be sure to use Pb free solder. For PCBs without Pb free mark, use standard solder.**

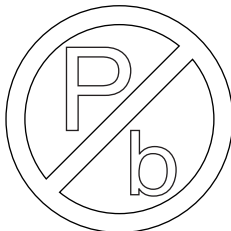

Pb free mark

## How to Remove / Install Flat Pack-IC

### 1. Removal

**With Hot-Air Flat Pack-IC Desoldering Machine:**

- (1) Prepare the hot-air flat pack-IC desoldering machine, then apply hot air to the Flat Pack-IC (about 5 to 6 seconds). (Fig. S-1-1)

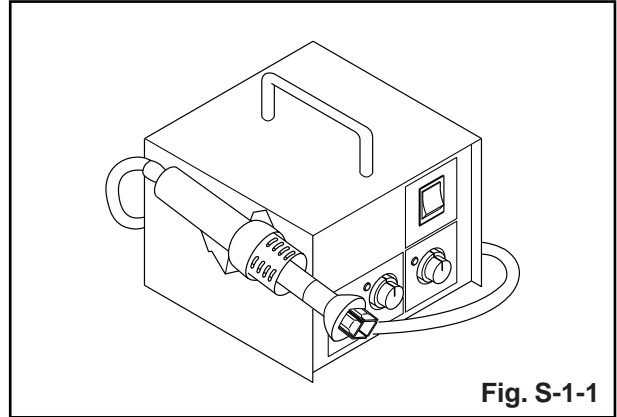

Fig. S-1-1

- (2) Remove the flat pack-IC with tweezers while applying the hot air.
- (3) Bottom of the flat pack-IC is fixed with glue to the CBA; when removing entire flat pack-IC, first apply soldering iron to center of the flat pack-IC and heat up. Then remove (glue will be melted). (Fig. S-1-6)
- (4) Release the flat pack-IC from the CBA using tweezers. (Fig. S-1-6)

### Caution:

1. The Flat Pack-IC shape may differ by models. Use an appropriate hot-air flat pack-IC desoldering machine, whose shape matches that of the Flat Pack-IC.
2. Do not supply hot air to the chip parts around the flat pack-IC for over 6 seconds because damage to the chip parts may occur. Put masking tape around the flat pack-IC to protect other parts from damage. (Fig. S-1-2)



3. The flat pack-IC on the CBA is affixed with glue, so be careful not to break or damage the foil of each pin or the solder lands under the IC when removing it.

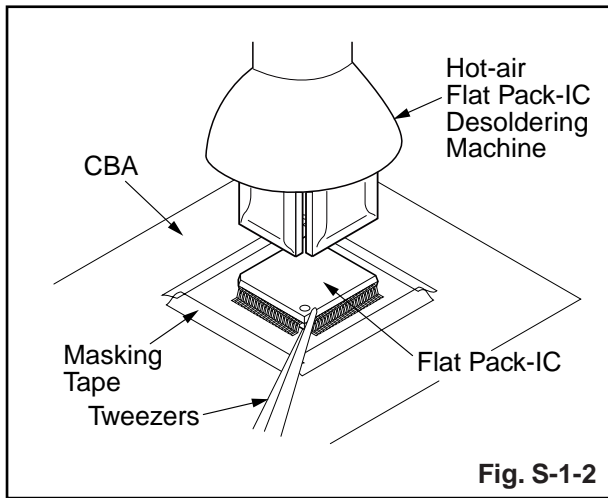

#### With Soldering Iron:

- (1) Using desoldering braid, remove the solder from all pins of the flat pack-IC. When you use solder flux which is applied to all pins of the flat pack-IC, you can remove it easily. (Fig. S-1-3)

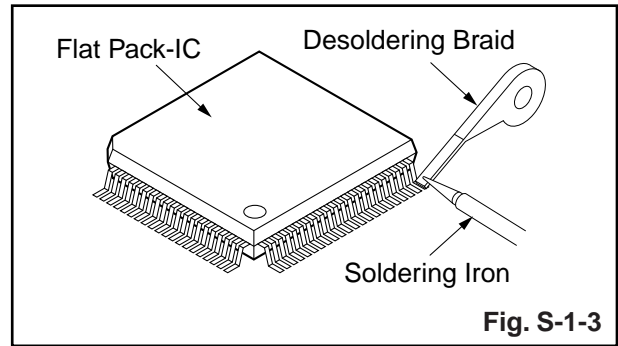

- (2) Lift each lead of the flat pack-IC upward one by one, using a sharp pin or wire to which solder will not adhere (iron wire). When heating the pins, use a fine tip soldering iron or a hot air desoldering machine. (Fig. S-1-4)

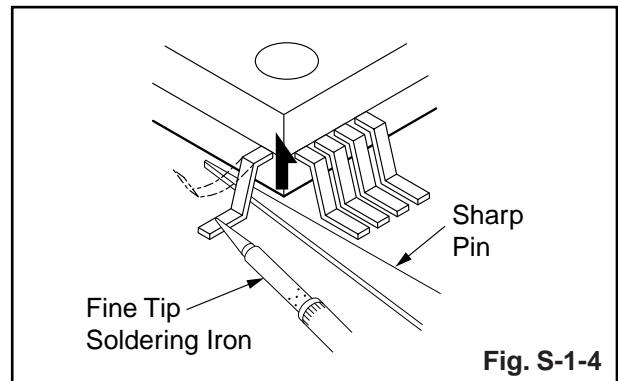

- (3) Bottom of the flat pack-IC is fixed with glue to the CBA; when removing entire flat pack-IC, first apply soldering iron to center of the flat pack-IC and heat up. Then remove (glue will be melted). (Fig. S-1-6)
- (4) Release the flat pack-IC from the CBA using tweezers. (Fig. S-1-6)

#### With Iron Wire:

- (1) Using desoldering braid, remove the solder from all pins of the flat pack-IC. When you use solder flux which is applied to all pins of the flat pack-IC, you can remove it easily. (Fig. S-1-3)
- (2) Affix the wire to a workbench or solid mounting point, as shown in Fig. S-1-5.
- (3) While heating the pins using a fine tip soldering iron or hot air blower, pull up the wire as the solder melts so as to lift the IC leads from the CBA contact pads as shown in Fig. S-1-5.
- (4) Bottom of the flat pack-IC is fixed with glue to the CBA; when removing entire flat pack-IC, first apply

soldering iron to center of the flat pack-IC and heat up. Then remove (glue will be melted). (Fig. S-1-6)

- (5) Release the flat pack-IC from the CBA using tweezers. (Fig. S-1-6)

**Note:**

When using a soldering iron, care must be taken to ensure that the flat pack-IC is not being held by glue. When the flat pack-IC is removed from the CBA, handle it gently because it may be damaged if force is applied.

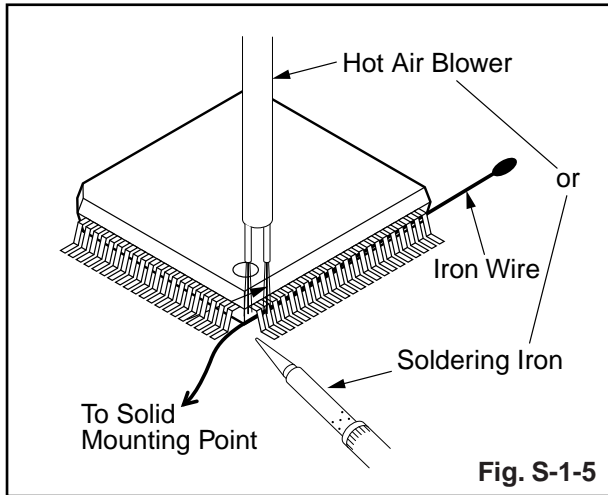

Fig. S-1-5

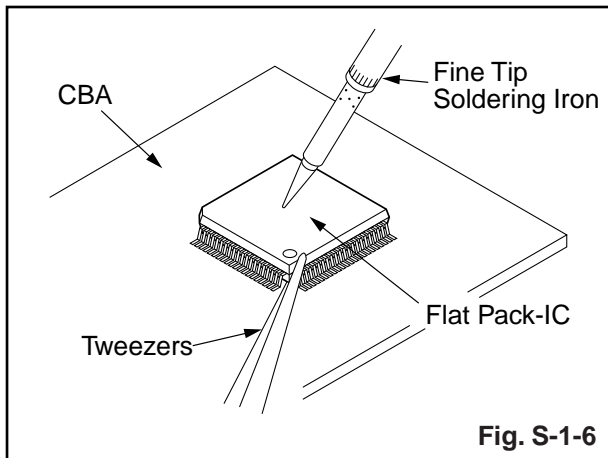

Fig. S-1-6

**2. Installation**

- (1) Using desoldering braid, remove the solder from the foil of each pin of the flat pack-IC on the CBA so you can install a replacement flat pack-IC more easily.
- (2) The "●" mark on the flat pack-IC indicates pin 1. (See Fig. S-1-7.) Be sure this mark matches the 1 on the PCB when positioning for installation. Then pre-solder the four corners of the flat pack-IC. (See Fig. S-1-8.)
- (3) Solder all pins of the flat pack-IC. Be sure that none of the pins have solder bridges.

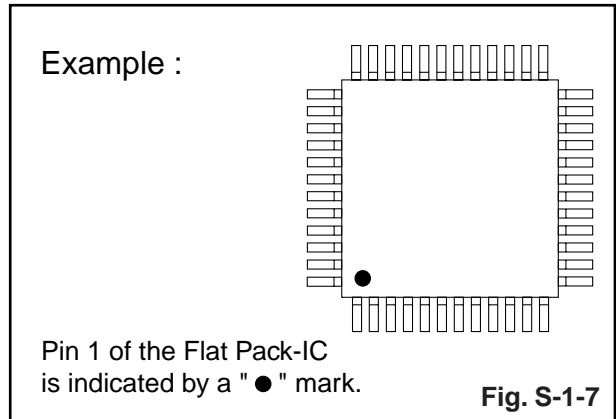

Fig. S-1-7

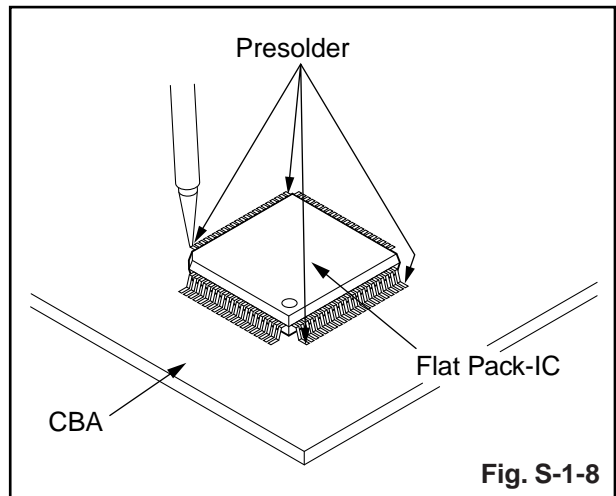

Fig. S-1-8

# Instructions for Handling Semiconductors

Electrostatic breakdown of the semiconductors may occur due to a potential difference caused by electrostatic charge during unpacking or repair work.

## 1. Ground for Human Body

Be sure to wear a grounding band ( $1M\Omega$ ) that is properly grounded to remove any static electricity that may be charged on the body.

## 2. Ground for Workbench

Be sure to place a conductive sheet or copper plate with proper grounding ( $1M\Omega$ ) on the workbench or other surface, where the semiconductors are to be placed. Because the static electricity charge on clothing will not escape through the body grounding band, be careful to avoid contacting semiconductors with your clothing.

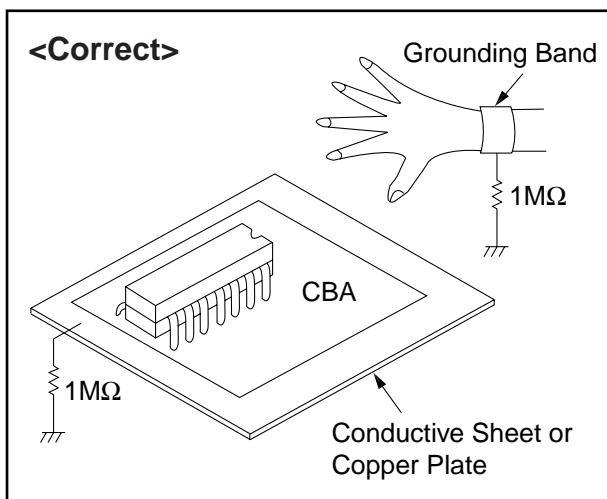
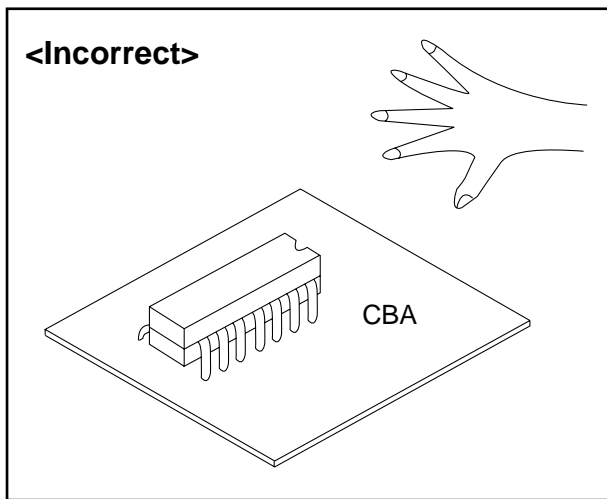

# CABINET DISASSEMBLY INSTRUCTIONS

## 1. Disassembly Flowchart

This flowchart indicates the disassembly steps for the cabinet parts, and the CBA in order to gain access to item(s) to be serviced. When reassembling, follow the steps in reverse order. Bend, route and dress the cables as they were.

### Caution !

When removing the CRT, be sure to discharge the Anode Lead of the CRT with the CRT Ground Wire before removing the Anode Cap.

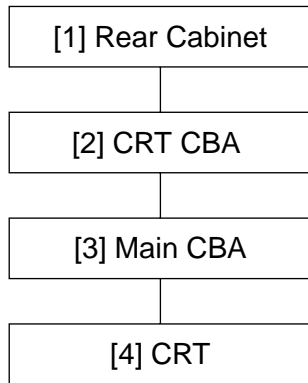

## 2. Disassembly Method

Step/ Loc. No.	Part	Removal		
		Fig. No	Remove/*unlock/ release/unplug/ unclamp/desolder	Note
[1]	Rear Cabinet	1,2	7(S-1), 1(S-2), 1(S-4)	1
[2]	CRT CBA	4,5	CN501	2
[3]	Main CBA	3,5	CN571	3
[4]	CRT	4	4(S-3), Anode Cap	4

↓            ↓            ↓            ↓            ↓  
 (1)        (2)        (3)            (4)            (5)

### Note :

- (1) Order of steps in procedure. When reassembling, follow the steps in reverse order. These numbers are also used as the Identification (location) No. of parts in figures.
- (2) Parts to be removed or installed.
- (3) Fig. No. showing procedure of part location
- (4) Identification of part to be removed, unhooked, unlocked, released, unplugged, unclamped, or desoldered.  
 S=Screw, P=Spring, L=Locking Tab, CN=Connector, \*=Unhook, Unlock, Release, Unplug, or Desolder  
 2(S-2) = two Screws (S-2)
- (5) Refer to the following "Reference Notes in the Table."

### Reference Notes in the Table

1. Removal of the Rear Cabinet. Remove screws 7(S-1), 1(S-2) and 1(S-4) then slide the Rear Cabinet backward.
2. Removal of the CRT CBA. Disconnect CN1501 then pull the CRT CBA backward.
3. Removal of the Main CBA. Disconnect CN571 on the Main CBA then slide the Main CBA backward.

### Caution:

Discharge the Anode Lead of the CRT with the CRT Ground Wire before removing the Anode Cap.

4. Removal of the CRT. Remove screws 4(S-3) and Anode Cap. then slide the CRT backward.

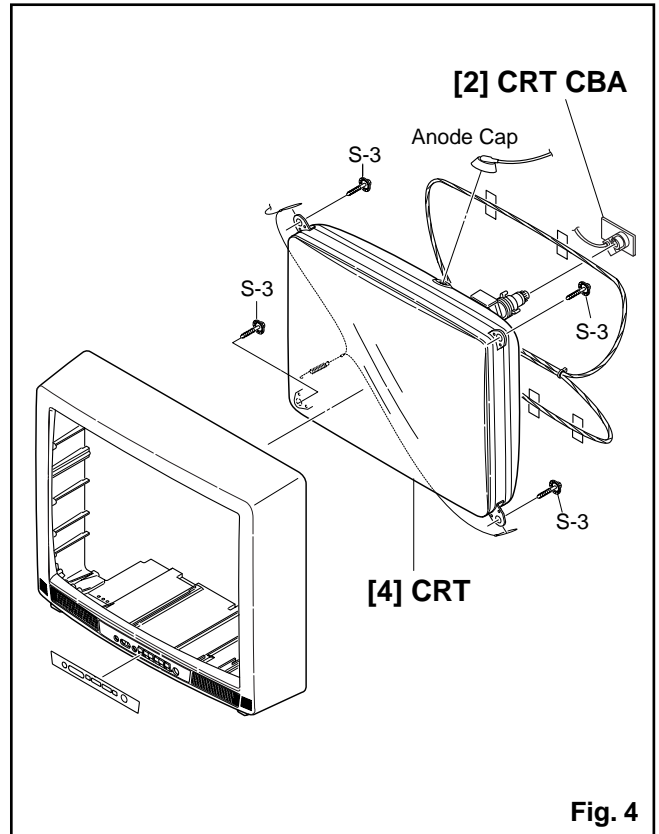
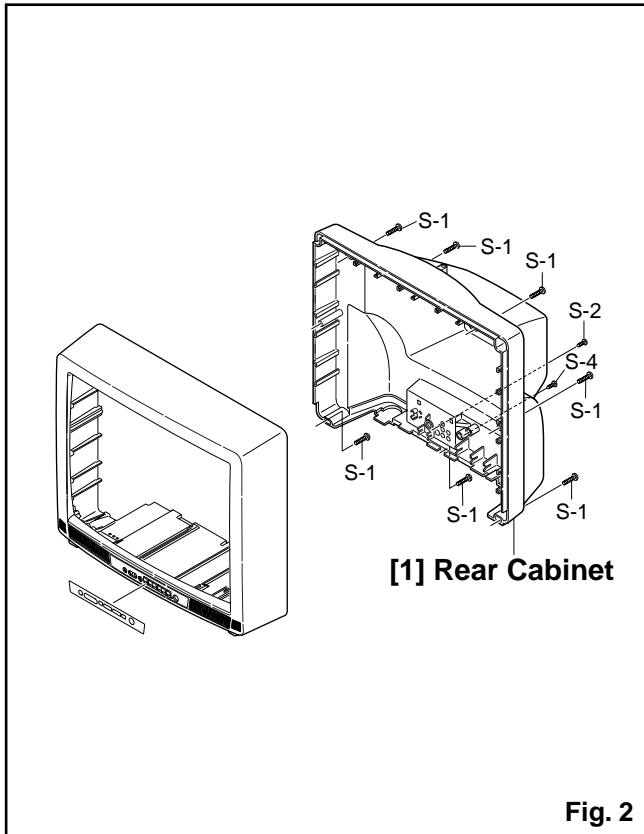
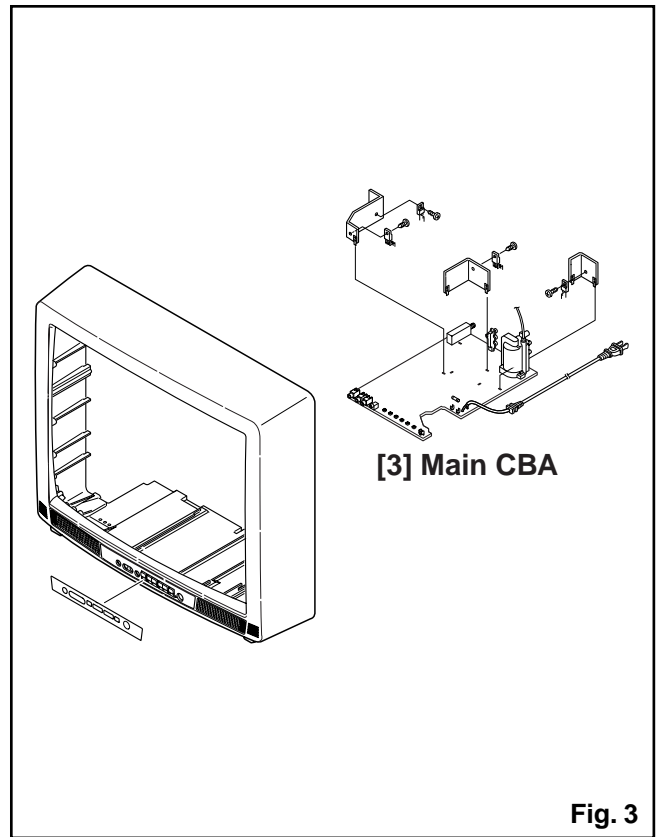
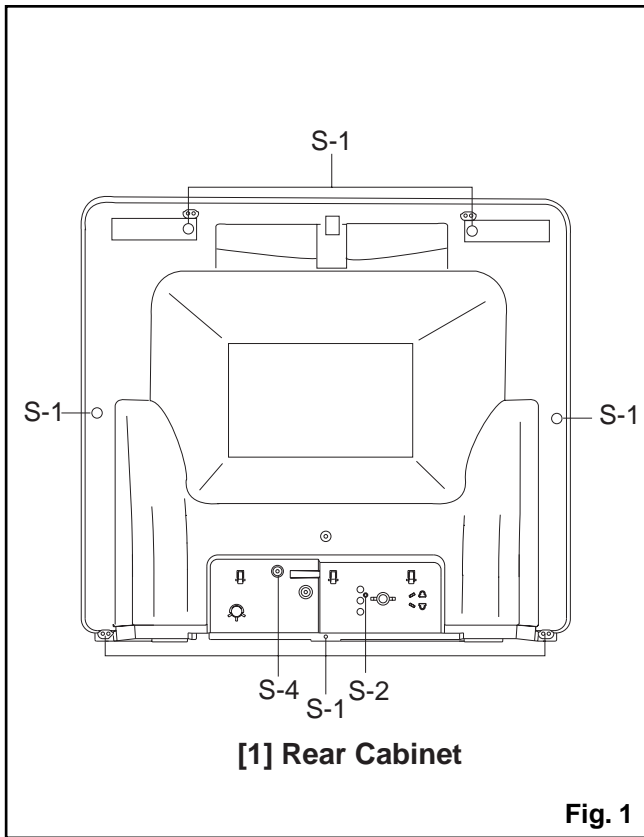

# TV Cable Wiring Diagram

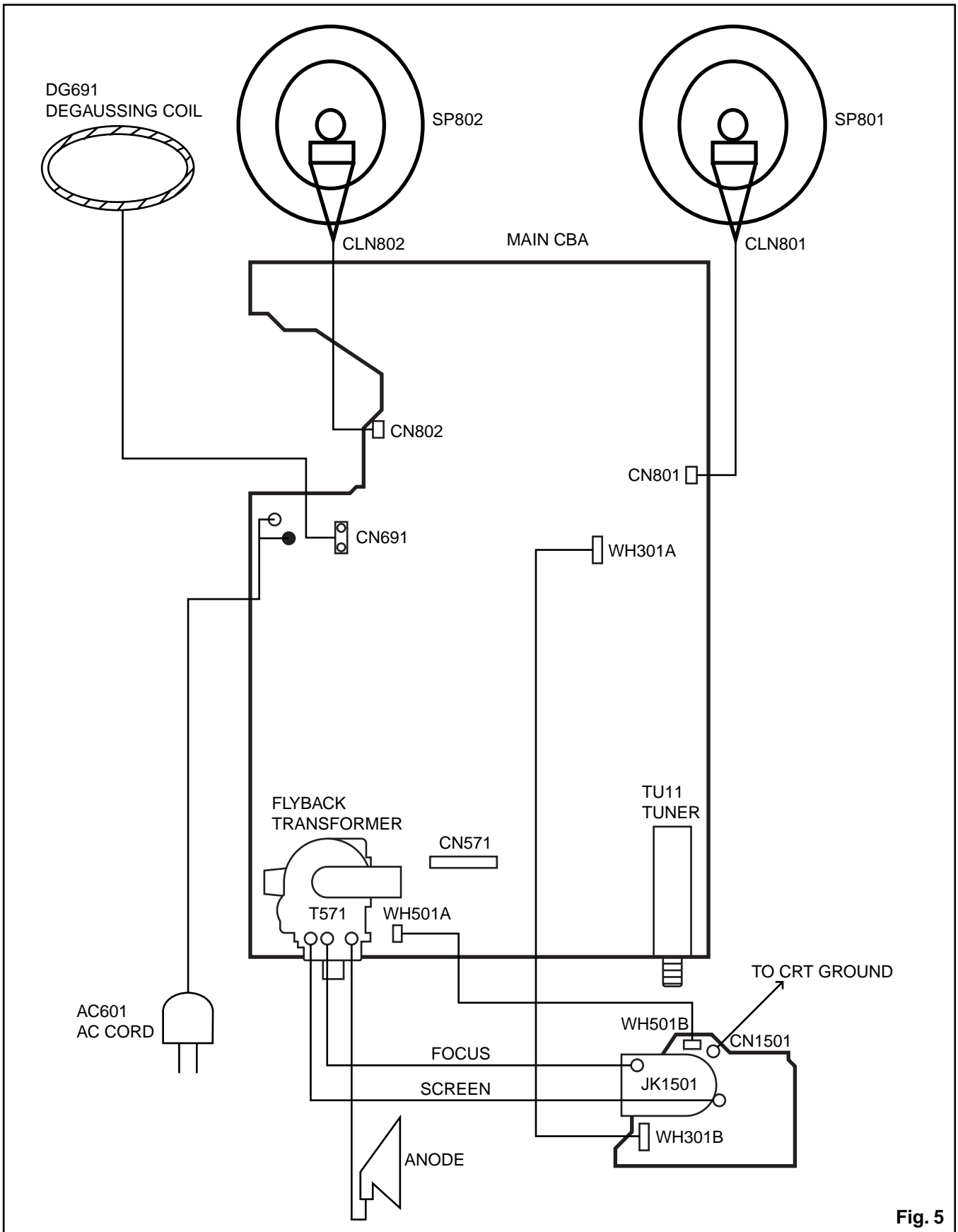

Fig. 5

# ELECTRICAL ADJUSTMENT INSTRUCTIONS

## General Note:

"CBA" is abbreviation for "Circuit Board Assembly."

## NOTE:

Electrical adjustments are required after replacing circuit components and certain mechanical parts. It is important to perform these adjustments only after all repairs and replacements have been completed.

Also, do not attempt these adjustments unless the proper equipment is available.

## Test Equipment Required

1. NTSC Pattern Generator (Color Bar W/White Window, Red Color, Dot Pattern, Gray Scale, Monoscope, Multi-Burst)
2. DC Voltmeter
3. Oscilloscope: Dual-trace with 10:1 probe, V-Range:0.001~50V/Div, F-Range: DC~AC-60MHz
4. Plastic Tip Driver
5. Remote control unit: Part No. N0108UD, N0132UD, NE121UD or NE122UD
6. DC power supply 13.2V/5A

## How to make Service remote control unit:

1. Prepare normal remote control unit. (Part No. N0108UD, N0132UD, NE121UD or NE122UD) Remove 3 Screws from the back lid. (Fig. 1-1)
2. Add J1 (Jumper Wire) to the remote control CBA. (Fig. 1-2)

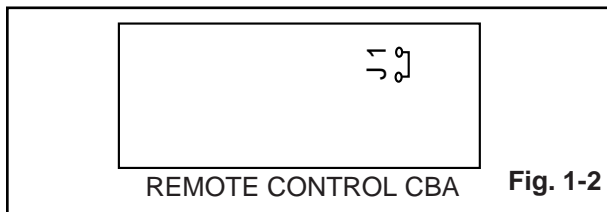
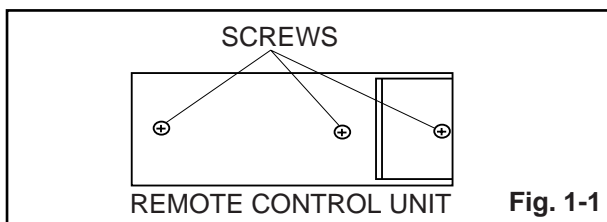

## How to set up the service mode:

### Service mode:

1. Use the service remote control unit.
2. Turn the power on. (Use main power on the TV unit.)
3. Press "SLEEP" button on the service remote control unit. Version of micro computer will display on the CRT. (Ex: 058-0.06)
4. Check the display on the lower left is "2640" and if it is not "2640," set it at "2640" according to "2. Initial Setting."

## 1. +B Adjustment

**Purpose:** To obtain correct operation.

**Symptom of Misadjustment:** The picture is dark and the unit does not operate correctly.

Test Point	Adj. Point	Mode	Input
TP601(+B) TP300(GND)	VR661	---	---
Tape	M. EQ.	Spec.	
---	DC Voltmeter	+120±0.5V DC.	

**Note:** TP601, TP300(GND), VR661 --- Main CBA

1. Connect DC Volt Meter to TP601 and TP300(GND).
2. Adjust VR661 so that the voltage of TP601 becomes +120±0.5V DC.

## 2. Initial Setting

### General

1. Enter the Service mode. (See page 5-1)
2. Press "VOL ▼" button on the service remote control unit. Display changes "C/D," "7F," "LANGUAGE," "ACCESS CODE," "SOUND TYPE," "VIDEO TONE," "FM MODE," "V-OUT," "VIDEO," "AV MEMO," "STABLE SOUND," "FILTER," "500," "YUV MEMORY," "NO SIG BRT," "A-MUTE POL," and "V-MENU" cyclically when "VOL ▼" button is pressed.
3. To set the following each data value, press "CH ▲ / ▼" buttons on the service remote control unit.

**7F --- Set to "FF."**

**LANGUAGE --- Set to "SPA/FRA."**

**ACCESS CODE --- Set to "OFF."**

**SOUND TYPE --- Set to "MTS."**

**VIDEO TONE --- Set to "ON."**

**FM-MODE --- Set to "OFF."**

**V-OUT --- Set to "OFF."**

**VIDEO --- Set to "V1."**

**AV MEMO --- Set to "OFF."**

**STABLE SOUND --- Set to "OFF."**

**FILTER --- Set to "OFF."**

**Adjusting the monitoring time --- Set to "500."**

**YUV MEMORY --- Set to "OFF."**

**NO SIG BRT --- Set to "0."**

**A-MUTE POL --- Set to "H."**

**V-MENU --- Set to "OFF."**

## 3. Setting for BRIGHT, CONTRAST, COLOR, TINT, and SHARPNESS data Values

### General

1. Enter the Service mode. (See page 5-1)
2. Press "MENU" button on the service remote control unit. Display changes "BRT," "CNT," "CLR," "TNT," "V-TNT" and "SHARP" cyclically when "MENU" button is pressed.

### CNT

1. Press "MENU" button on the service remote control unit. Then select "CONTRAST" (CNT) display.
2. Press "CH ▲/▼" buttons on the service remote control unit so that the value of "CONTRAS" (CNT) becomes 84.

### CLR

1. Press "MENU" button on the service remote control unit. Then select "COLOR" (CLR) display.
2. Press "CH ▲/▼" buttons on the service remote control unit so that the value of "COLOR" (CLR) becomes 56.

### TNT

1. Press "MENU" button on the service remote control unit. Then select "TINT" (TNT) display.
2. Press "CH ▲/▼" buttons on the service remote control unit so that the value of "TINT" (TNT) becomes 58.

### V-TNT

1. Press "MENU" button on the service remote control unit. Then select "V-TINT" (V-TNT) display.
2. Press "CH ▲/▼" buttons on the service remote control unit so that the value of "V-TINT" (V-TNT) becomes 59.

### SHARP

1. Press "MENU" button on the service remote control unit. Then select "SHARPNESS" (SHARP) display.
2. Press "CH ▲/▼" buttons on the service remote control unit and select "47."

**Note:** BRIGHT data value does not need to be adjusted at this moment.

## 4. H f<sub>0</sub> Adjustment

**Purpose:** To get correct horizontal frequency.

Use service remote control unit.

1. Press "2" button on the service remote control unit. and select H-ADJ mode. (By pressing "2" button the display will change from TV AGC to H-ADJ.)
2. Press "CH ▲/▼" button on the service remote control unit so that display will change "0" ~ "7". At this moment, Choose "4".
3. Turn the power off and on again. (Main Power button on the TV unit.)



## 5. Black Stretch Control Adjustment

**Purpose:** To show the fine black color.

**Symptom of Misadjustment:** Black color will not appear correctly.

**Note:** Use service remote control unit.

1. Enter the Service mode. (See page 5-1)
2. Press "6" button on the service remote control unit. "B-S" is indicated.
3. Press "CH ▲ / ▼" buttons on the service remote control unit so that display will change "OFF," "0," and "1." Then choose "B-S OFF."
4. Press "6" button on the service remote control unit. "B-S2" is indicated.
5. Press "CH ▲ / ▼" buttons on the service remote control unit so that display will change "0" and "1." Then choose "B-S2 0."
6. Turn the power off and on again, using the main power button on the TV unit.

## 6. Purity Check

1. Enter the Service mode. (See page 5-1)
2. Press "7" button on the remote control unit. Each time pressing 7" button on the remote control unit, display changes Red mode, Green mode, Blue mode, and White mode cyclically.
3. Select White mode.
4. Turn the power off and on again. (Main power button on the TV unit.)

## 7. SD Check Mode

1. Enter the Service mode. (See page 5-1)
2. Press "1" button on the remote control unit. The unit enter the SD-Check mode.
3. The unit starts selecting the added channel from first channel according to the memorized CH ADD/ DELL data and CATV/TV data in RAM.

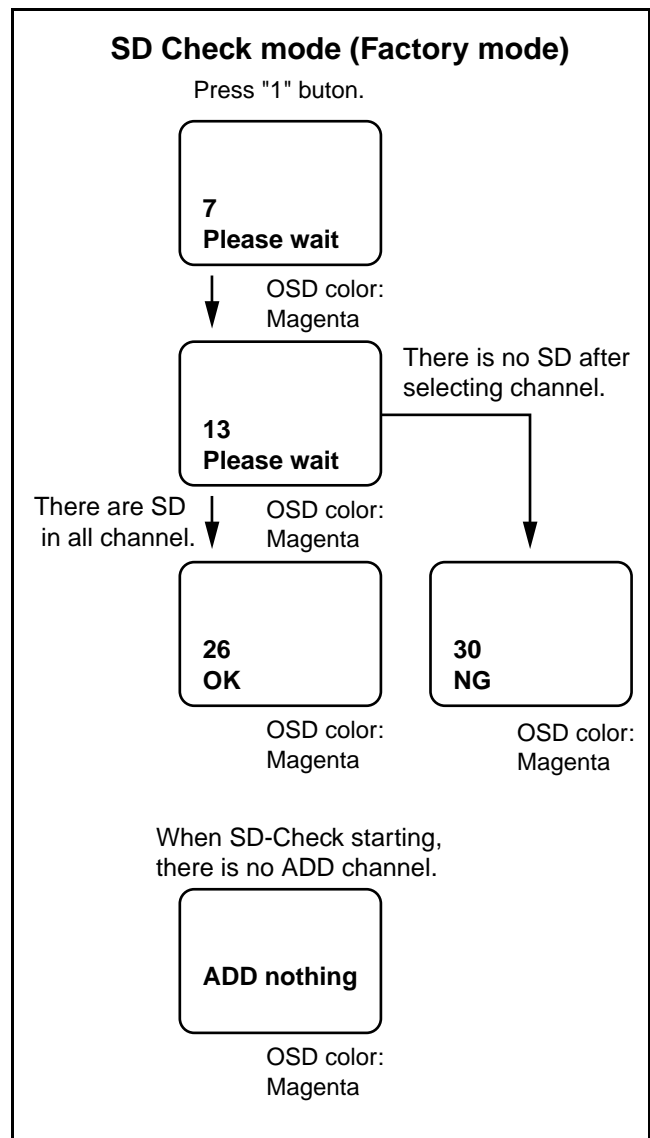

## 8. H. Position Adjustment

**Purpose:** To obtain correct horizontal position of screen image.

**Symptom of Misadjustment:** If H. Position is incorrect, horizontal position of image on the screen may not be properly displayed.

Test Point	Adj. Point	Mode	Input
---	CH ▲ / ▼ buttons	RF	Monoscope
<b>Tape</b>	<b>M. EQ.</b>	<b>Spec.</b>	
---	Monoscope	90±5%	

**Note:** Use service remote control unit

1. Operate the unit for at least 20 minutes.
2. Enter the Service mode. (See page 5-1)
3. Receive the monoscope pattern.
4. Press "8" button on the remote control unit. "H-P" is indicated.
5. Press "CH ▲/▼" buttons on the service remote control unit so that the monoscope pattern will be 90±5% of display size and the circle is round.
6. Turn the power off and on again. (Main power button on the TV unit.)

## 9. V. Size Adjustment

**Purpose:** To obtain correct vertical width of screen image.

**Symptom of Misadjustment:** If V. Size is incorrect, vertical size of image on the screen may not be properly displayed.

Test Point	Adj. Point	Mode	Input
---	CH ▲ / ▼ buttons	RF	Monoscope
<b>Tape</b>	<b>M. EQ.</b>	<b>Spec.</b>	
---	Monoscope	90±5%	

**Note:** Use service remote control unit.

1. Operate the unit for at least 20 minutes.
2. Enter the Service mode. (See page 5-1)
3. Receive the monoscope pattern.
4. Press "9" button on the service remote control unit and select "V-S" mode. (Display changes "V-S" and "V-P" cyclically when "9" button is pressed).
5. Press "CH ▲/▼" buttons on the service remote control unit so that the monoscope pattern will be 90±5% of display size and the circle is round.
6. Turn the power off and on again. (Main power button on the TV unit.)

## 10. V. Position Adjustment

**Purpose:** To obtain correct vertical width of screen image.

**Symptom of misadjustment:** If V. Position is incorrect, vertical height of image on the screen may not be properly displayed.

Test Point	Adj. Point	Mode	Input
---	CH ▲ / ▼ buttons	RF	Monoscope
<b>Tape</b>	<b>M. EQ.</b>	<b>Spec.</b>	
---	Monoscope	See below.	

**Note:** Use service remote control unit

1. Operate the unit for at least 20 minutes.
2. Enter the Service Mode. (See page 5-1)
3. Receive the monoscope pattern.
4. Press "9" button on the service remote control unit and select "V-P" mode. (Display change "V-S" and "V-P" cyclically when "9" button is pressed).
5. Press "CH ▲/▼" buttons on the service remote control unit so that the top and bottom of the monoscope pattern will be equal of each other.
6. Turn the power off and on again. (Main power button on the TV unit.)

## 11. Software Reset

To reset software, press "5" button on the remote control unit for at least 5 seconds after pressing "CH RETURN" button on the remote control unit.

## 12. H. Size Adjustment

**Purpose:** To obtain correct horizontal size of screen image.

**Symptom of Misadjustment:** If H. Size is incorrect, horizontal size of image on the screen may not be properly displayed.

Test Point	Adj. Point	Mode	Input
---	VR562	RF	Monoscope
<b>Tape</b>	<b>M. EQ.</b>	<b>Spec.</b>	
---	Monoscope	90±5%	

**Note:** Use service remote control unit

1. Operate the unit for at least 20 minutes.
2. Receive the Monoscope Pattern.
3. Adjust VR562 so that the monoscope pattern will be 90±5% of display size and circle is round.
4. Turn the Power off and on again. (Main power button on the TV unit.)

### 13. PIN Cushion Adjustment

**Purpose:** To obtain correct straight vertical line of screen image.

**Symptom of Misadjustment:** If H.Pin cushion is incorrect, vertical line of image on the screen may not be properly displayed.

Test Point	Adj. Point	Mode	Input
---	VR561	RF	Cross hatch
Tape	M. EQ.	Spec.	
---	Cross hatch		

**Note:** Use service remote control unit

1. Operate the unit for at least 20 minutes.
2. Receive the Cross hatch Pattern.
3. Adjust VR561 so that the cross hatch pattern will be straight line of display.
4. Turn the Power off and on again. (Main power button on the TV unit.)

### 14. Cut-off Adjustment

**Purpose:** To adjust the beam current of R, G, B, and screen voltage.

**Symptom of Misadjustment:** White color may be reddish, greenish or bluish.

Test Point	Adj. Point	Mode	Input
---	Screen-Control CH ▲ / ▼ buttons	RF	Black Raster
Tape	M. EQ.	Spec.	
---	Pattern Generator	See Reference Notes below.	

**Figure**

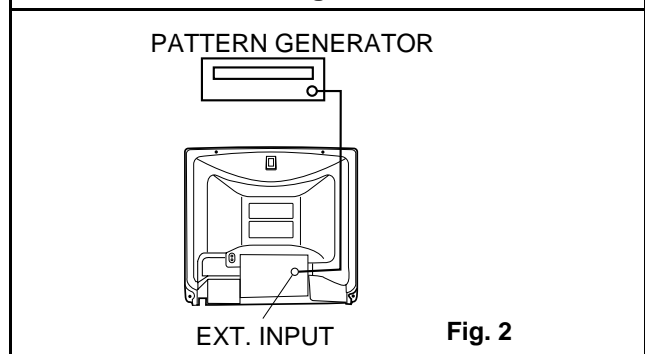

**Fig. 2**

**Note:** Screen Control FBT --- Main CBA  
F.B.T= Fly Back Transformer  
Use service remote control unit

1. Degauss the CRT and allow CRT to operate for 20 minutes before starting the alignment.
2. Input the Black Raster Signal from RF Input.
3. Enter the Service mode. (See page 5-1)
4. Press "VOL ▼" button on the service remote control unit and select "C/D" mode. (Display changes "C/D," "7F," "LANGUAGE," "ACCESS CODE," "SOUND TYPE," "VIDEO TONE," "FM MODE," "V-OUT," "VIDEO," "AV MEMO," "STABLE SOUND," "FILTER," "500," "YUV MEMORY," "NO SIG BRT," "A-MUTE POL," and "V-MENU" cyclically when "VOL ▼" button is pressed.) then press "1." The display will momentarily show "CUT OFF R" (R= Red). Now there should be a horizontal line across the center of the picture tube. If needed gradually turn the screen control on the flyback, clockwise until the horizontal line appears. Adjust the Red Cut off by pressing the "CH ▲/▼" buttons. Proceed to Step 5 when the Red Cut off adjustment is done.
5. Press the "2" button. The display will momentarily show "CUT OFF G" (G=Green). Adjust the Green Cut off by pressing the "CH ▲/▼" buttons. Proceed to step 6 when the Green Cut off adjustment is done.
6. Press the "3" button. The display will momentarily show "CUT OFF B" (B=Blue). Adjust the Blue cut off by pressing the "CH ▲/▼" buttons. When done with steps 4, 5 and 6 the horizontal line should be pure white if not, then attempt the Cut off adjustment again.

## 15. White Balance Adjustment

**Purpose:** To mix red, green and blue beams correctly for pure white.

**Symptom of Misadjustment:** White becomes bluish or reddish.

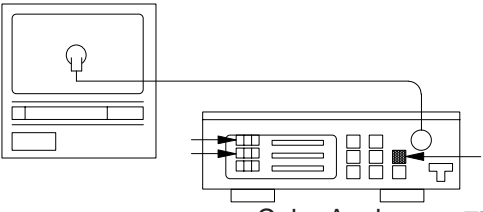
Test Point	Adj. Point	Mode	Input
Screen	CH ▲ / ▼ buttons	RF	White Raster (APL 100%)
<b>Tape</b>	<b>M. EQ.</b>	<b>Spec.</b>	
---	Pattern Generator, Color analyzer	See below	
<b>Figure</b>			
			

**Note:** Use service remote control unit

- Operate the unit more than 20 minutes.
- Face the unit to east. Degauss the CRT using Degaussing Coil.
- Input the White Raster (APL 100%).
- Set the color analyzer to the CHROMA mode and after zero point calibration, bring the optical receptor to the center on the tube surface (CRT).
- Enter the Service mode. Press "VOL ▼" button on the service remote control unit and select "C/D" mode. (Display changes "C/D," "7F," "LANGUAGE," "ACCESS CODE," "SOUND TYPE," "VIDEO TONE," "FM MODE," "V-OUT," "VIDEO," "AV MEMO," "STABLE SOUND," "FILTER," "500," "YUV MEMORY," "NO SIG BRT," "A-MUTE POL," and "V-MENU" cyclically when "VOL ▼" button is pressed.) then Press No. 8 button on the service remote control Unit.
- Press No. 4 button on the service remote control unit for Red adjustment. Press NO. 5 button on the service remote control unit for Blue adjustment.
- In each color mode, Press "CH ▲/▼" button to adjust the values of color.
- Adjusting Red and Blue color so that the temperature becomes 9200K (x: 286 / y: 294)±3%.
- At this time, Re-check that Horizontal line is white. If not, Re-adjust Cut-off Adjustment until the Horizontal Line becomes pure white.
- Turn off and on again to return to normal mode. Receive APL 100% white signal and Check Chroma temperatures become 9200K (x: 286 / y: 294)±3%.

**Note:** Confirm that Cut Off Adj. is correct after this adjustment, and attempt Cut Off Adj. if needed.

## 16. Sub-Brightness Adjustment

**Purpose:** To get proper brightness.

**Symptom of Misadjustment:** If Sub-Brightness is incorrect, proper brightness cannot be obtained by adjusting the Brightness Control.

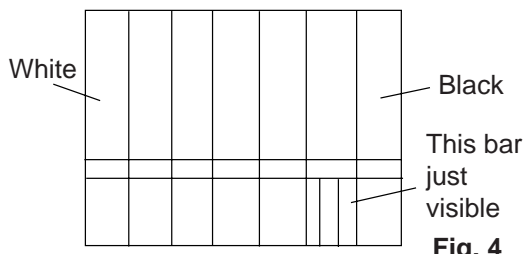
Test Point	Adj. Point	Mode	Input
---	CH ▲ / ▼ buttons	RF	IQW
<b>Tape</b>	<b>M. EQ.</b>	<b>Spec.</b>	
---	Pattern Generator	See below	
<b>Figure</b>			
			

**Note:** IQW Setup level --- 7.5 IRE

Use service remote control unit

- Enter the Service mode. (See page 5-1) Then input IQW signal from RF Input.
- Press "MENU" button on the service remote control unit and Select "BRT" mode. (Display changes "BRT," "CNT," "CLR," "TNT," "V-TNT," and "SHARP" cyclically when "MENU" button is pressed). Press "CH ▲/▼" buttons so that the bar is just visible (See above figure).
- Turn the power off and on again. (Main power button on the TV unit.)

## 17. Focus Adjustment

**Purpose:** Set the optimum Focus.

**Symptom of Misadjustment:** If Focus Adjustment is incorrect, blurred images are shown on the display.

Test Point	Adj. Point	Mode	Input
---	Focus Control	---	Monoscope
<b>Tape</b>	<b>M. EQ.</b>	<b>Spec.</b>	
---	Pattern Generator	See below	

**Note:** Focus VR (FBT) - Main CBA, FBT=Fly Back Transformer

- Operate the unit more than 30 minutes.
- Face the unit to the East and Degauss the CRT using Degaussing Coil.
- Input the Monoscope Pattern.
- Adjust the Focus Control on the FBT to obtain clear picture.

The following adjustments normally are not attempted in the field. Only when replacing the CRT then adjust as a preparation.

## 18. Purity Adjustment

**Purpose:** To obtain pure color.

**Symptom of Misadjustment:** If Color Purity Adjustment is incorrect, large areas of color may not be properly displayed.

Test Point	Adj. Point	Mode	Input
---	Deflection Yoke Purity Magnet	---	Red Color
Tape	M. EQ.	Spec.	
---	Pattern Generator	See below.	

Figure

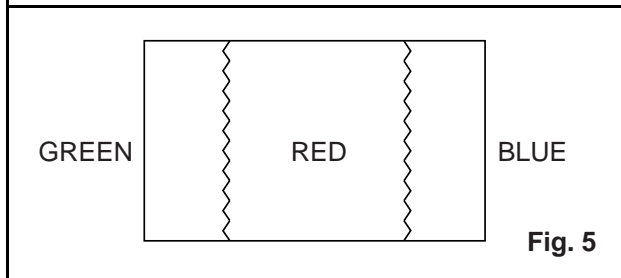

1. Set the unit facing east.
2. Operate the unit for over 30 minutes before adjusting.
3. Fully degauss the unit using an external degaussing coil.
4. Loosen the screw on the Deflection Yoke Clamper and pull the Deflection Yoke back away from the screen. (See Fig. 6)
5. Loosen the Ring Lock and adjust the Purity Magnets so that a red field is obtained at the center of the screen. Tighten Ring Lock. (See Fig. 5,6)
6. Slowly push the Deflection Yoke toward bell of CRT and set it where a uniform red field is obtained.
7. Tighten the clamp screw on the Deflection Yoke.

## 19. Convergence Adjustment

**Purpose:** To obtain proper convergence of red, green and blue beams.

**Symptom of Misadjustment:** If Convergence Adjustment is incorrect, the edge of white letters may have color edges.

Test Point	Adj. Point	Mode	Input
---	C.P. Magnet (RB), C.P. Magnet (RB-G), Deflection Yoke	---	Dot Pattern or Crosshatch
Tape	M. EQ.	Spec.	
---	Pattern Generator	See below.	

Figures

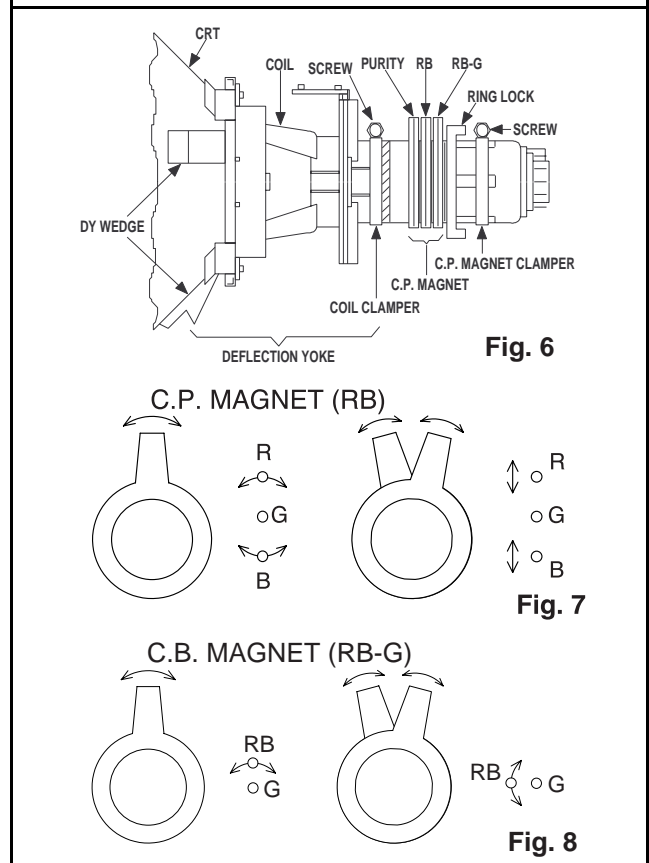

1. Loosen the Ring Lock and align red with blue dots or Crosshatch at the center of the screen by rotating (RB) C.P. Magnets. (See Fig. 7)
2. Align red / blue with green dots at the center of the screen by rotating (RB-G) C.P. Magnet. (See Fig. 8)
3. Fix the C.P. Magnets by tightening the Ring Lock.
4. Remove the DY Wedges and slightly tilt the Deflection Yoke horizontally and vertically to obtain the best overall convergence.
5. Fix the Deflection Yoke by carefully inserting the DY Wedges between CRT and Deflection Yoke.

# BLOCK DIAGRAMS

## System Control Block Diagram

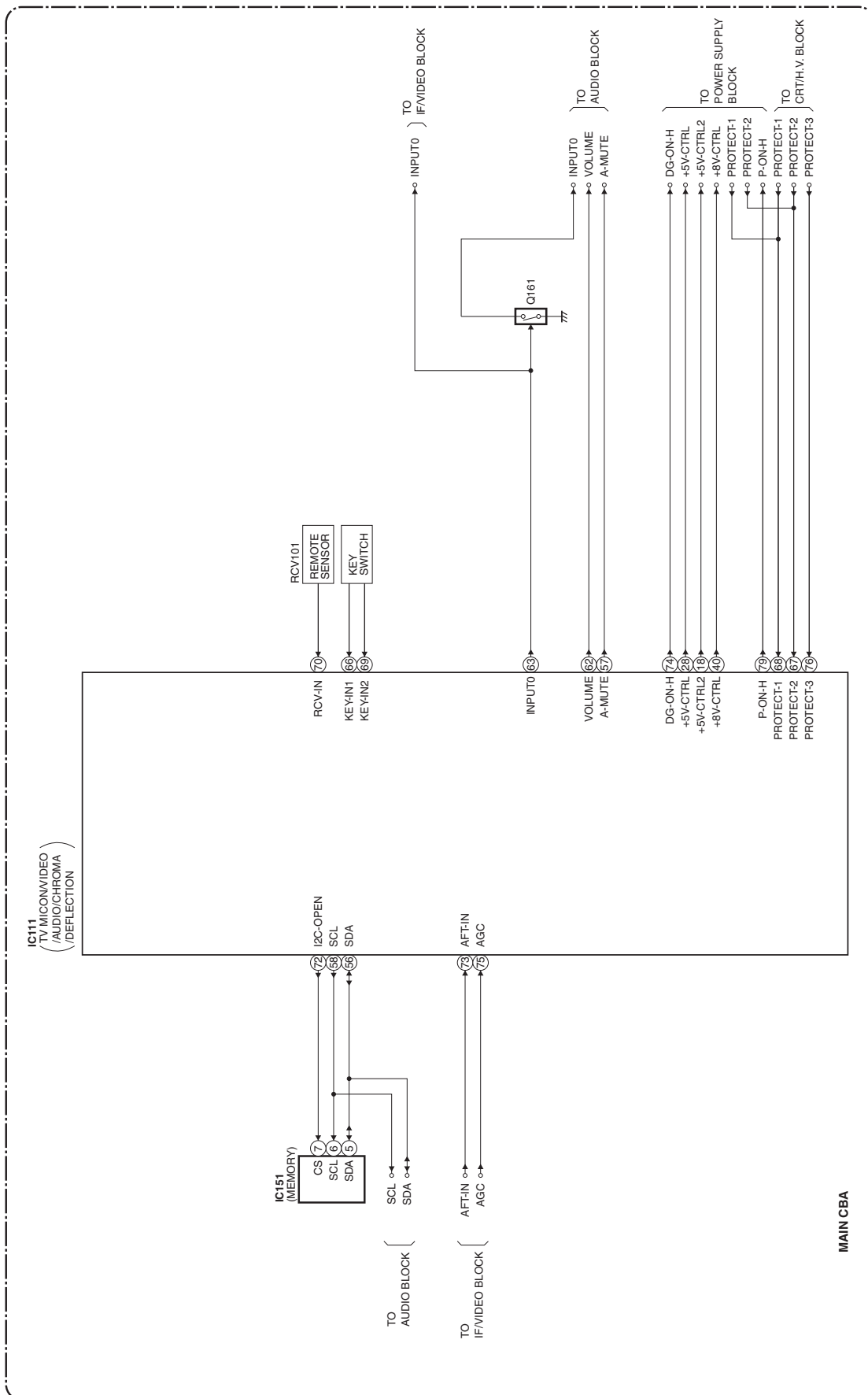

# IF/Video Block Diagram

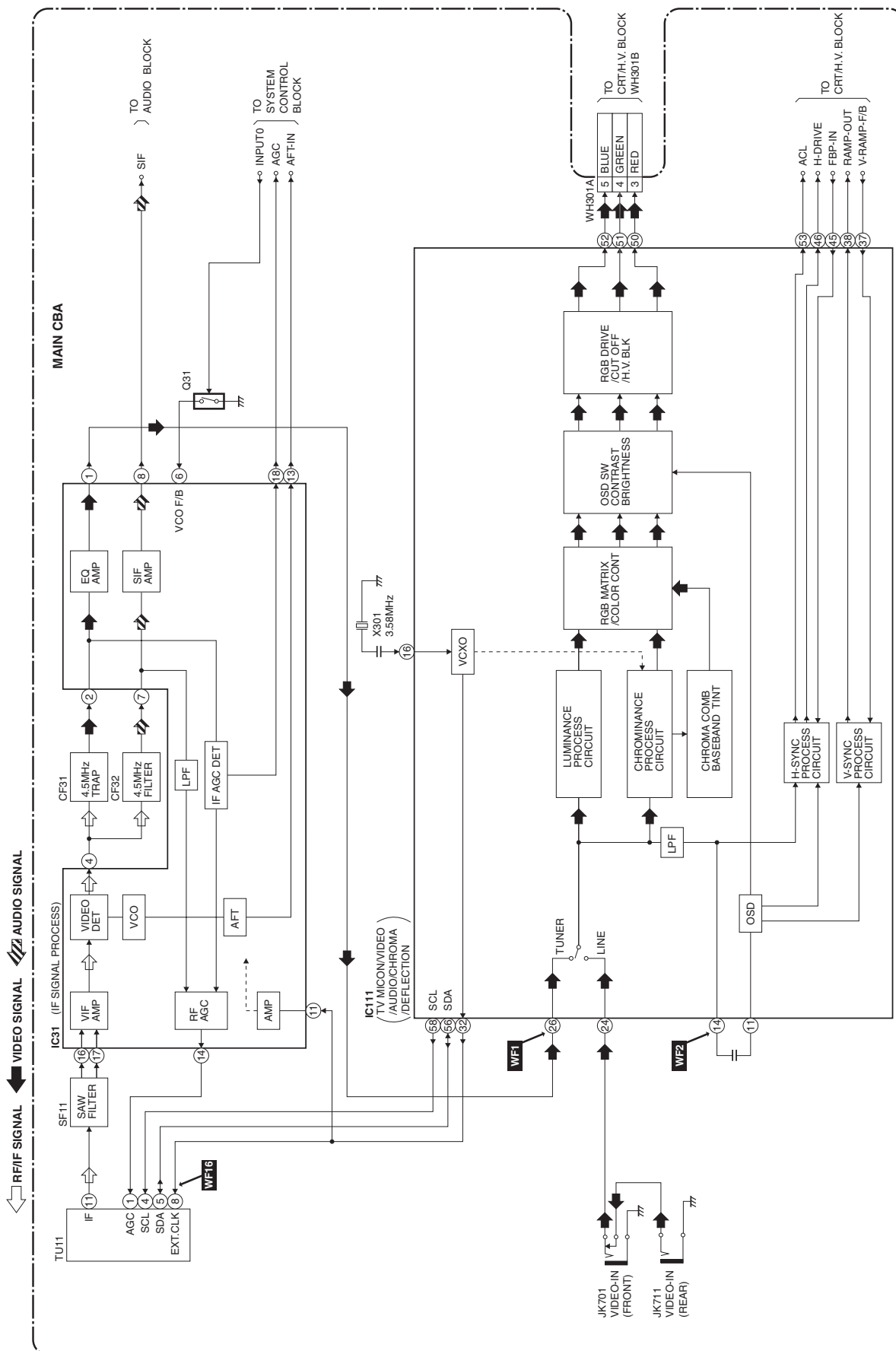







# Power Supply Block Diagram

**CAUTION !**

Fixed voltage ( or Auto voltage selectable ) power supply circuit is used in this unit.  
 If Main Fuse (F601) is blown, check to see that all components in the power supply circuit are not defective before you connect the AC plug to the AC power supply.  
 Otherwise it may cause some components in the power supply circuit to fail.



**CAUTION:** FOR CONTINUED PROTECTION AGAINST RISK OF FIRE,  
 REPLACE ONLY WITH SAME TYPE 4 A, 125V FUSE.  
**ATTENTION:** UTILISER UN FUSIBLE DE RECHANGE DE MEME TYPE DE 4A, 125V.

**NOTE :**

The voltage for parts in hot circuit is measured using hot GND as a common terminal.

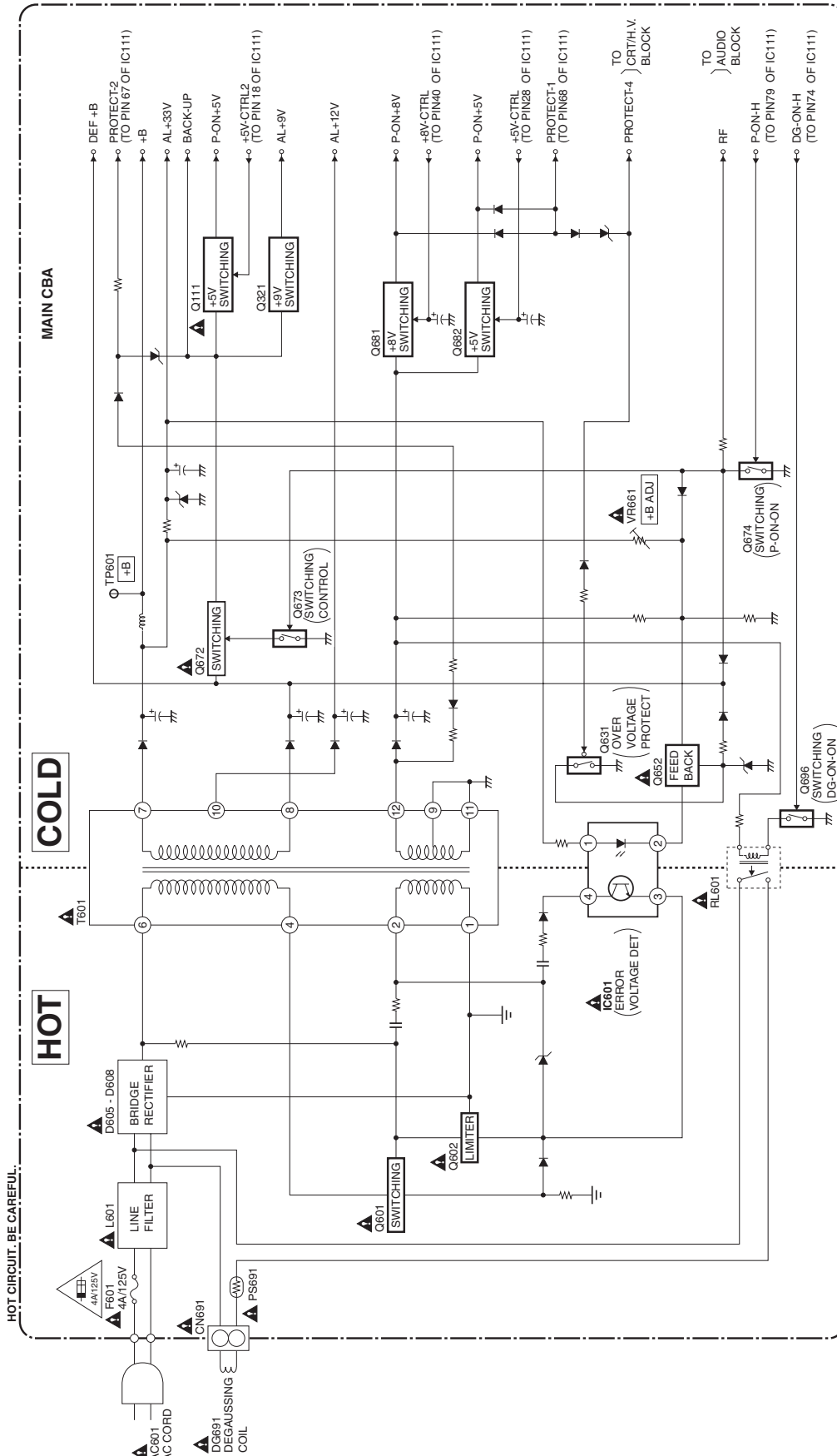

# SCHEMATIC DIAGRAMS / CBA'S AND TEST POINTS

## Standard Notes

Many electrical and mechanical parts in this chassis have special characteristics. These characteristics often pass unnoticed and the protection afforded by them cannot necessarily be obtained by using replacement components rated for higher voltage, wattage, etc. Replacement parts that have these special safety characteristics are identified in this manual and its supplements; electrical components having such features are identified by the mark "▲" in the schematic diagram and the parts list. Before replacing any of these components, read the parts list in this manual carefully. The use of substitute replacement parts that do not have the same safety characteristics as specified in the parts list may create shock, fire, or other hazards.

### Note:

1. Do not use the part number shown on these drawings for ordering. The correct part number is shown in the parts list, and may be slightly different or amended since these drawings were prepared.
2. All resistance values are indicated in ohms ( $K=10^3$ ,  $M=10^6$ ).
3. Resistor wattages are 1/4W or 1/6W unless otherwise specified.
4. All capacitance values are indicated in  $\mu F$  ( $P=10^{-6}\mu F$ ).
5. All voltages are DC voltages unless otherwise specified.

### Note of Capacitors:

ML --- Mylar Cap.    PP --- Metallized Film Cap.    SC --- Semiconductor Cap.    L --- Low Leakage type

### Temperature Characteristics of Capacitors are noted with the following:

B ---  $\pm 10\%$     CH ---  $0\pm 60\text{ppm}/^\circ\text{C}$     CSL ---  $+350\sim -1000\text{ppm}/^\circ\text{C}$

### Tolerance of Capacitors are noted with the following:

Z ---  $+80\sim -20\%$

### Note of Resistors:

CEM --- Cement Res.    MTL --- Metal Res.    F --- Fuse Res.

### Capacitors and transistors are represented by the following symbols.

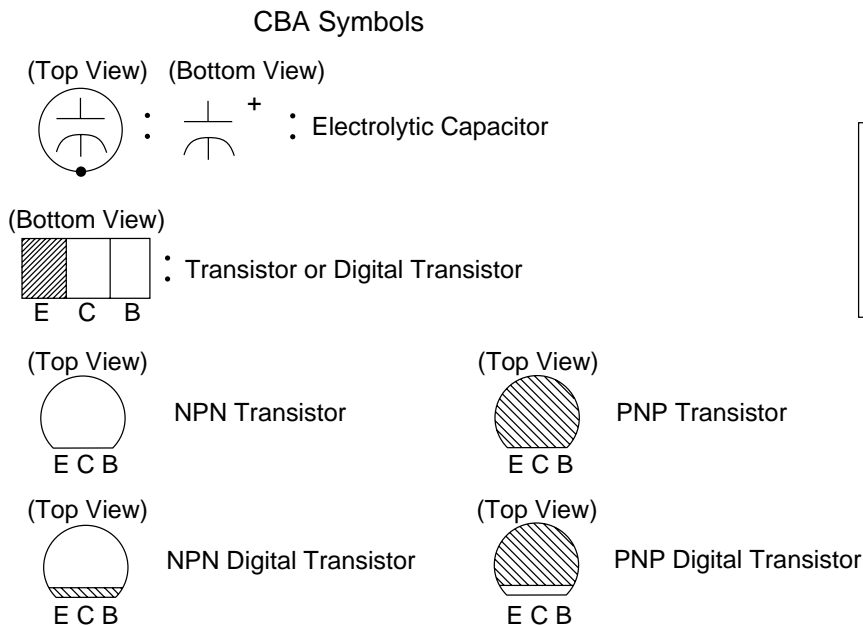

### Schematic Diagram Symbols

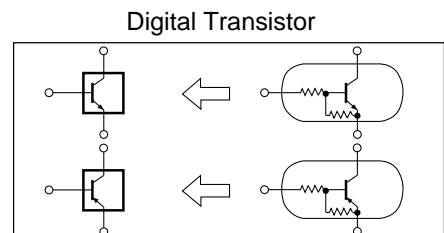

**LIST OF CAUTION, NOTES, AND SYMBOLS USED IN THE SCHEMATIC DIAGRAMS ON THE FOLLOWING PAGES:**

**1. CAUTION:** FOR CONTINUED PROTECTION AGAINST RISK OF FIRE, REPLACE ONLY WITH SAME TYPE\_A,\_V FUSE.

**ATTENTION:** UTILISER UN FUSIBLE DE RECHANGE DE MÊME TYPE DE\_A,\_V.

**2. CAUTION:**

Fixed Voltage (or Auto voltage selectable) power supply circuit is used in this unit.

If Main Fuse (F601) is blown, first check to see that all components in the power supply circuit are not defective before you connect the AC plug to the AC power supply. Otherwise it may cause some components in the power supply circuit to fail.

**3. Note:**

(1) Do not use the part number shown on the drawings for ordering. The correct part number is shown in the parts list, and may be slightly different or amended since the drawings were prepared.

(2) To maintain original function and reliability of repaired units, use only original replacement parts which are listed with their part numbers in the parts list section of the service manual.

**4. Wire Connectors**

(1) Prefix symbol "CN" means "connector" (can disconnect and reconnect).

(2) Prefix symbol "CL" means "wire-solder holes of the PCB" (wire is soldered directly).

**5. Note:** Mark "●" is a leadless (chip) component.

**6. Voltage indications on the schematics are as shown below:**

Plug the TV power cord into a standard AC outlet.:

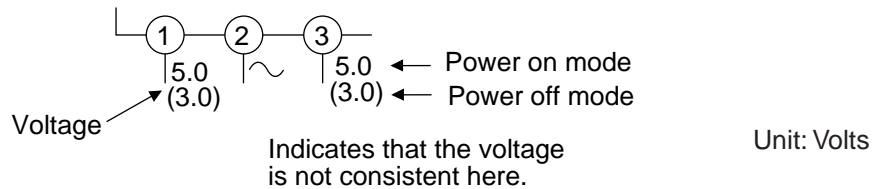

**7. How to read converged lines**

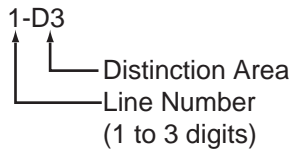

Examples:

1. "1-D3" means that line number "1" goes to area "D3".

2. "1-B1" means that line number "1" goes to area "B1".

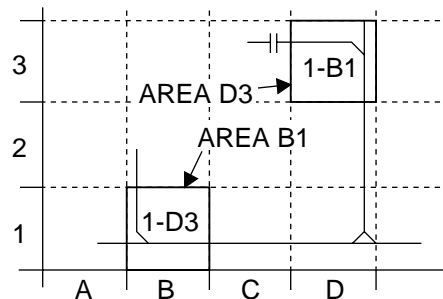

**8. Test Point Information**

⊕ : Indicates a test point with a jumper wire across a hole in the PCB.

□→ : Used to indicate a test point with a component lead on foil side.

⊗ : Used to indicate a test point with no test pin.

● : Used to indicate a test point with a test pin.





# Main 3/4 Schematic Diagram

- - - - - IF SIGNAL
- VIDEO SIGNAL
- ← AUDIO SIGNAL

**CAUTION !**  
 Fixed voltage ( or Auto voltage selectable ) power supply circuit is used in this unit.  
 If Main Fuse (F601) is blown, check to see that all components in the power supply circuit are not defective before you connect the AC plug to the AC power supply.  
 Otherwise it may cause some components in the power supply circuit to fail.

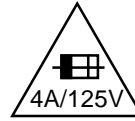

**CAUTION: FOR CONTINUED PROTECTION AGAINST RISK OF FIRE, REPLACE ONLY WITH SAME TYPE 4A, 125V FUSE. ATTENTION: UTILISER UN FUSIBLE DE RECHANGE DE MÊME TYPE DE 4A, 125V.**

**NOTE :**  
 The voltage for parts in hot circuit is measured using hot GND as a common terminal.

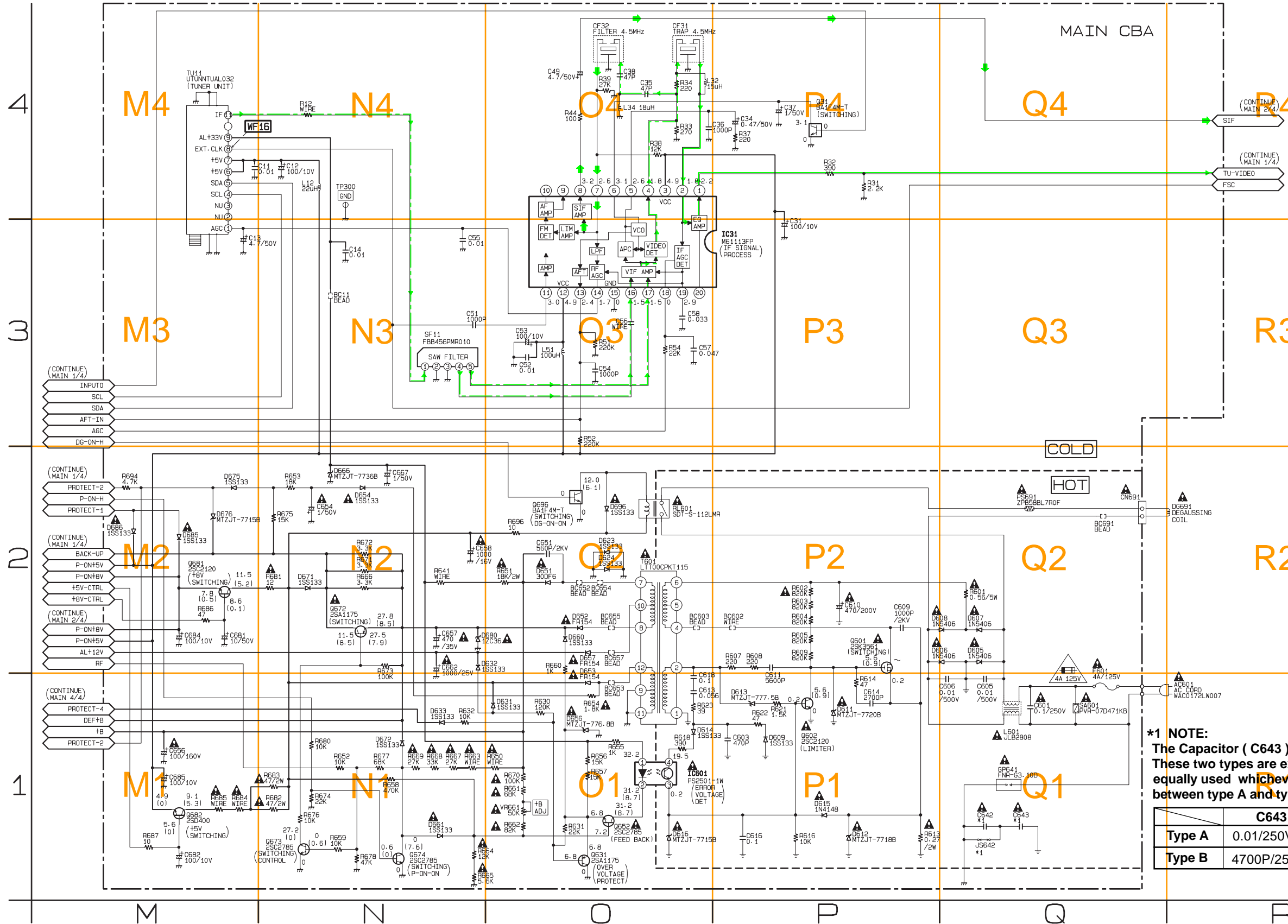

MAIN 3/4

Ref No.	Position
ICS	
IC31	P-3
IC601	O-1
TRANSISTORS	
Q31	P-4
Q601	P-2
Q602	P-1
Q631	O-1
Q652	O-1
Q672	N-2
Q673	N-1
Q674	N-1
Q681	M-2
Q682	M-1
Q696	O-2
CONNECTOR	
CN691	Q-2
TEST POINT	
TP300	N-4
VARIABLE RESISTOR	
VR661	O-1

**\*1 NOTE:**  
 The Capacitor ( C643 ) is either type A or type B. These two types are exchangeable and can be equally used whichever the model is . The difference between type A and type B is shown in the table below.

	C643	C642	JS642
Type A	0.01/250V	0.01/250V	Not Used
Type B	4700P/250V	Not Used	WIRE



# Main 4/4 & CRT Schematic Diagram

MAIN 4/4

Ref No.	Position	Ref No.	Position
IC		CONNECTORS	
IC551	S-3	CN571	T-3
TRANSISTORS		WH301A	V-2
Q511	S-2	WH501A	V-3
TEST POINTS			
Q547	U-2	TP591	U-2
Q551	T-3	TP592	U-2
Q552	T-3	TP601	U-2
Q561	U-3	VARIABLE RESISTORS	
Q571	U-2	VR561	U-3
Q572	T-2	VR562	U-3

CRT

Ref No.	Position
TRANSISTORS	
Q1511	W-1
Q1521	W-1
Q1531	X-1
CONNECTORS	
CN1501	X-2
WH301B	V-2
WH501B	V-3

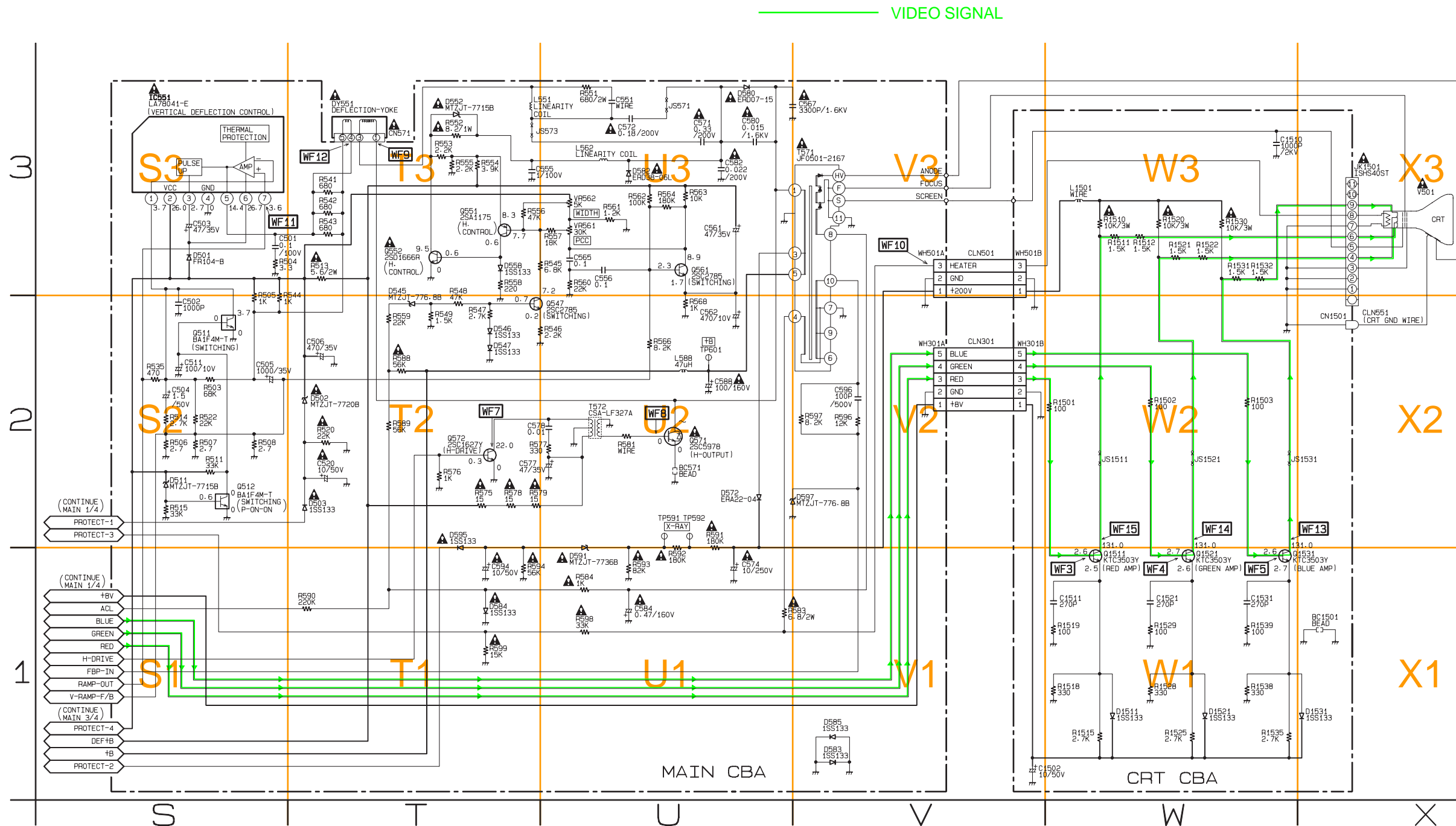



# Main CBA Top View

## CAUTION !

Fixed voltage ( or Auto voltage selectable ) power supply circuit is used in this unit.  
If Main Fuse (F601) is blown, check to see that all components in the power supply circuit are not defective before you connect the AC plug to the AC power supply.  
Otherwise it may cause some components in the power supply circuit to fail.

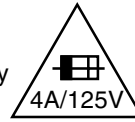

**CAUTION:** FOR CONTINUED PROTECTION AGAINST RISK OF FIRE, REPLACE ONLY WITH SAME TYPE 4A, 125V FUSE.  
**ATTENTION:** UTILISER UN FUSIBLE DE RECHANGE DE MÊME TYPE DE 4A, 125V.

## NOTE :

The voltage for parts in hot circuit is measured using hot GND as a common terminal.

**BECAUSE A HOT CHASSIS GROUND IS PRESENT IN THE POWER SUPPLY CIRCUIT, AN ISOLATION TRANSFORMER MUST BE USED. ALSO, IN ORDER TO HAVE THE ABILITY TO INCREASE THE INPUT SLOWLY, WHEN TROUBLESHOOTING THIS TYPE POWER SUPPLY CIRCUIT, A VARIABLE ISOLATION TRANSFORMER IS REQUIRED.**

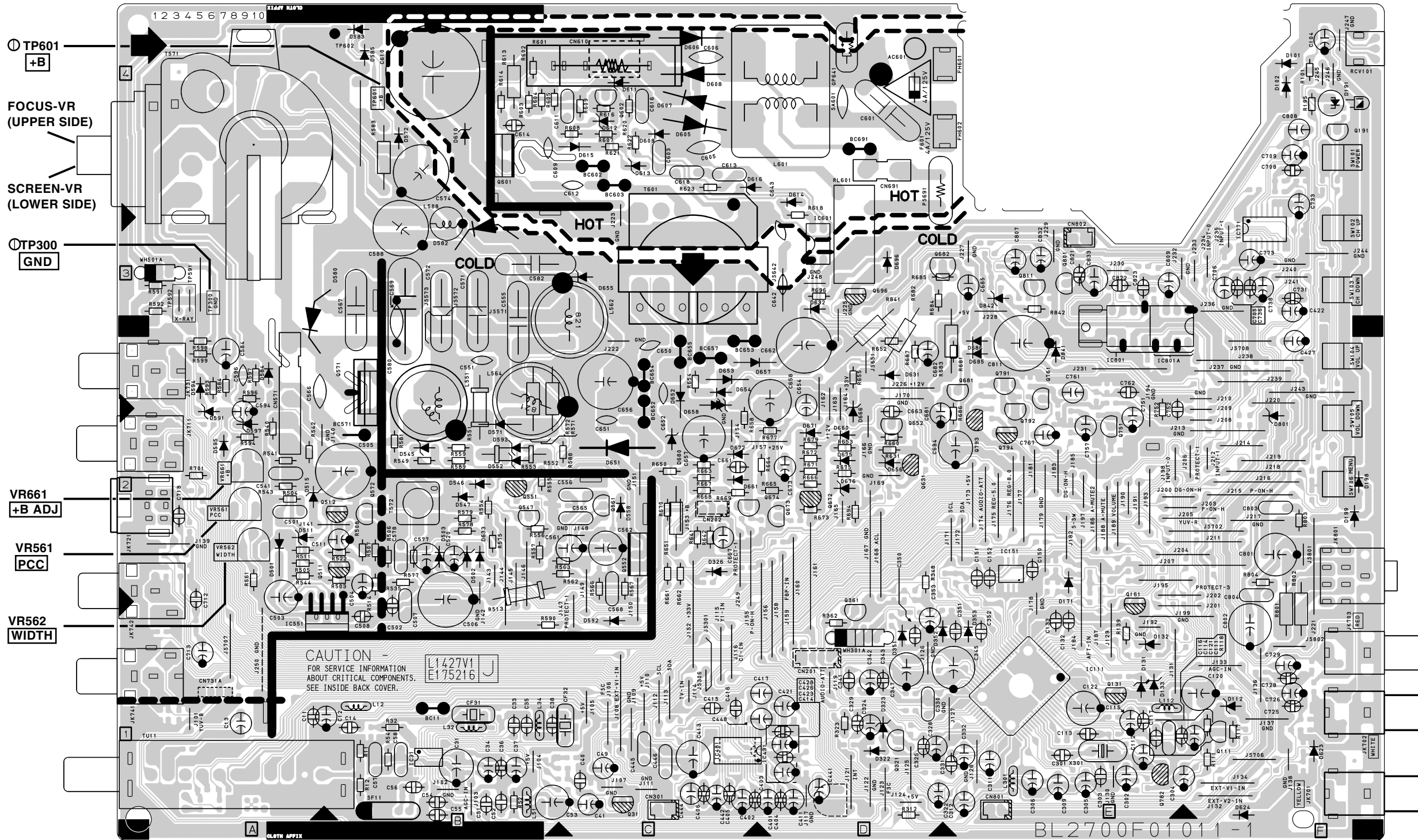

MAIN CBA	
Ref No.	Position
ICS	
IC31	B-1
IC111	E-1
IC151	E-2
IC431	D-1
IC551	A-1
IC601	D-3
IC801	E-3
TRANSISTORS	
Q31	C-1
Q111	F-1
Q161	E-1
Q321	D-1
Q361	D-1
Q511	A-2
Q512	B-2
Q547	B-2
Q551	B-2
Q552	C-2
Q561	C-2
Q571	B-3
Q572	B-2
Q601	B-4
Q602	C-4
Q631	D-2
Q652	D-2
Q672	D-2
Q673	D-2
Q674	D-3
Q681	E-3
Q682	D-3
Q696	D-3
Q801	E-3
Q811	E-3
CONNECTORS	
CN571	A-3
CN691	D-4
CN801	E-1
CN802	E-3
WH301A	D-1
WH501A	A-3
TEST POINTS	
TP300	A-3
TP591	A-3
TP592	A-3
TP601	B-4
VARIABLE RESISTORS	
VR561	A-2
VR562	A-2
VR661	A-2

# Main CBA Bottom View

## CAUTION !

Fixed voltage ( or Auto voltage selectable ) power supply circuit is used in this unit.  
 If Main Fuse (F601) is blown, check to see that all components in the power supply circuit are not defective before you connect the AC plug to the AC power supply.  
 Otherwise it may cause some components in the power supply circuit to fail.



**CAUTION:** FOR CONTINUED PROTECTION AGAINST RISK OF FIRE, REPLACE ONLY WITH SAME TYPE 4A, 125V FUSE.  
**ATTENTION:** UTILISER UN FUSIBLE DE RECHANGE DE MÊME TYPE DE 4A, 125V.

## NOTE :

The voltage for parts in hot circuit is measured using hot GND as a common terminal.

**BECAUSE A HOT CHASSIS GROUND IS PRESENT IN THE POWER SUPPLY CIRCUIT, AN ISOLATION TRANSFORMER MUST BE USED. ALSO, IN ORDER TO HAVE THE ABILITY TO INCREASE THE INPUT SLOWLY, WHEN TROUBLESHOOTING THIS TYPE POWER SUPPLY CIRCUIT, A VARIABLE ISOLATION TRANSFORMER IS REQUIRED.**



**WF6**  
 PIN 3  
 OF IC801

**WF8**

Q571  
 Base

**WF10**

PIN 3  
 OF WH501A

**WF9**

PIN 1  
 OF CN571

**WF12**

PIN 4  
 OF CN571

**WF7**

Q572  
 Collector

**WF11**

PIN 7  
 OF IC551

**WF1**

PIN 26  
 OF IC111

**WF16**

PIN 8  
 OF TU11

**WF2**

PIN 14  
 OF IC111

# CRT CBA Top View

# CRT CBA Bottom View

CRT CBA

Ref No.	Position
TRANSISTORS	
Q1511	A-2
Q1521	A-2
Q1531	A-2
CONNECTORS	
CN1501	B-1
WH301B	B-2
WH501B	B-1

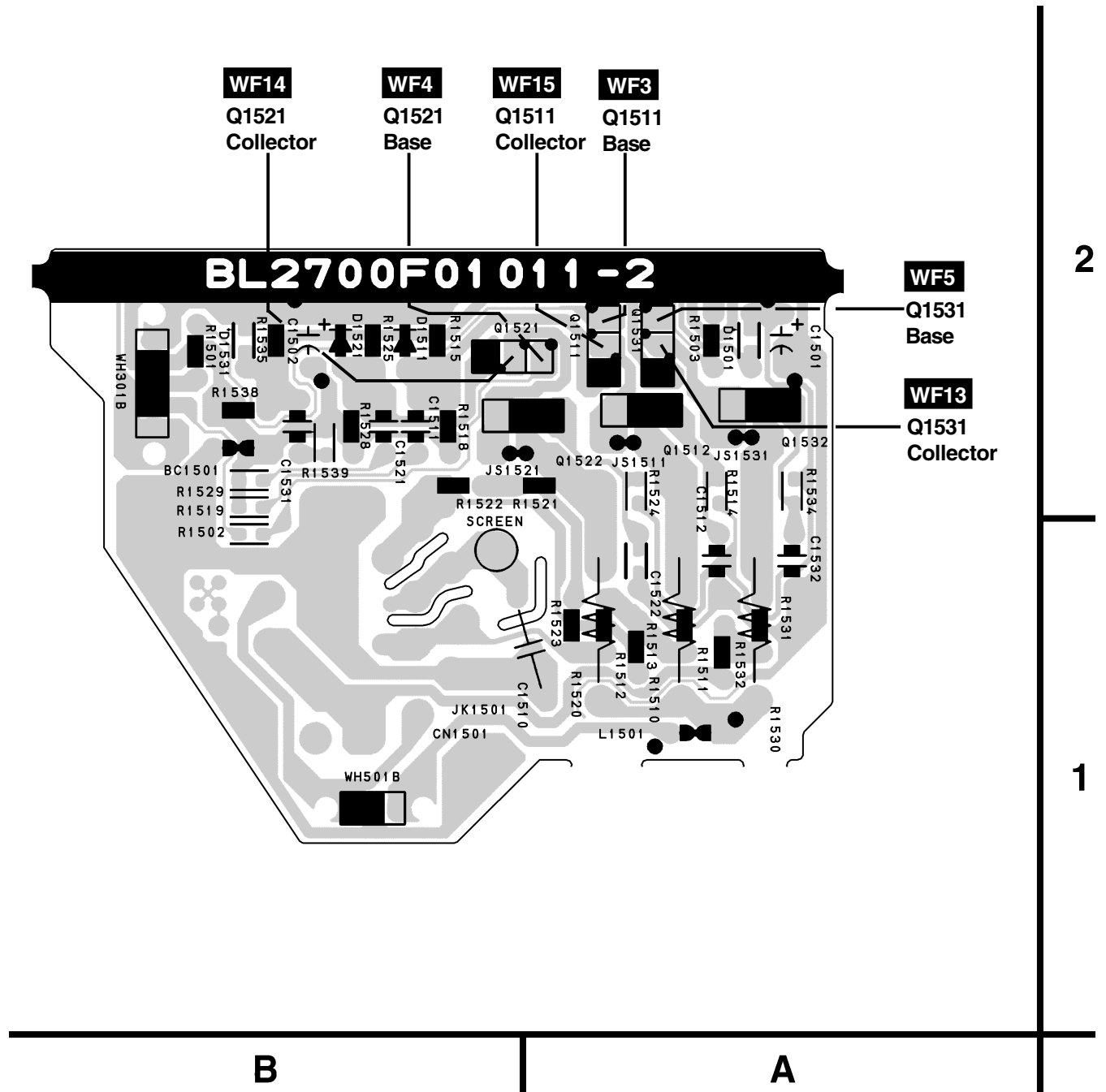
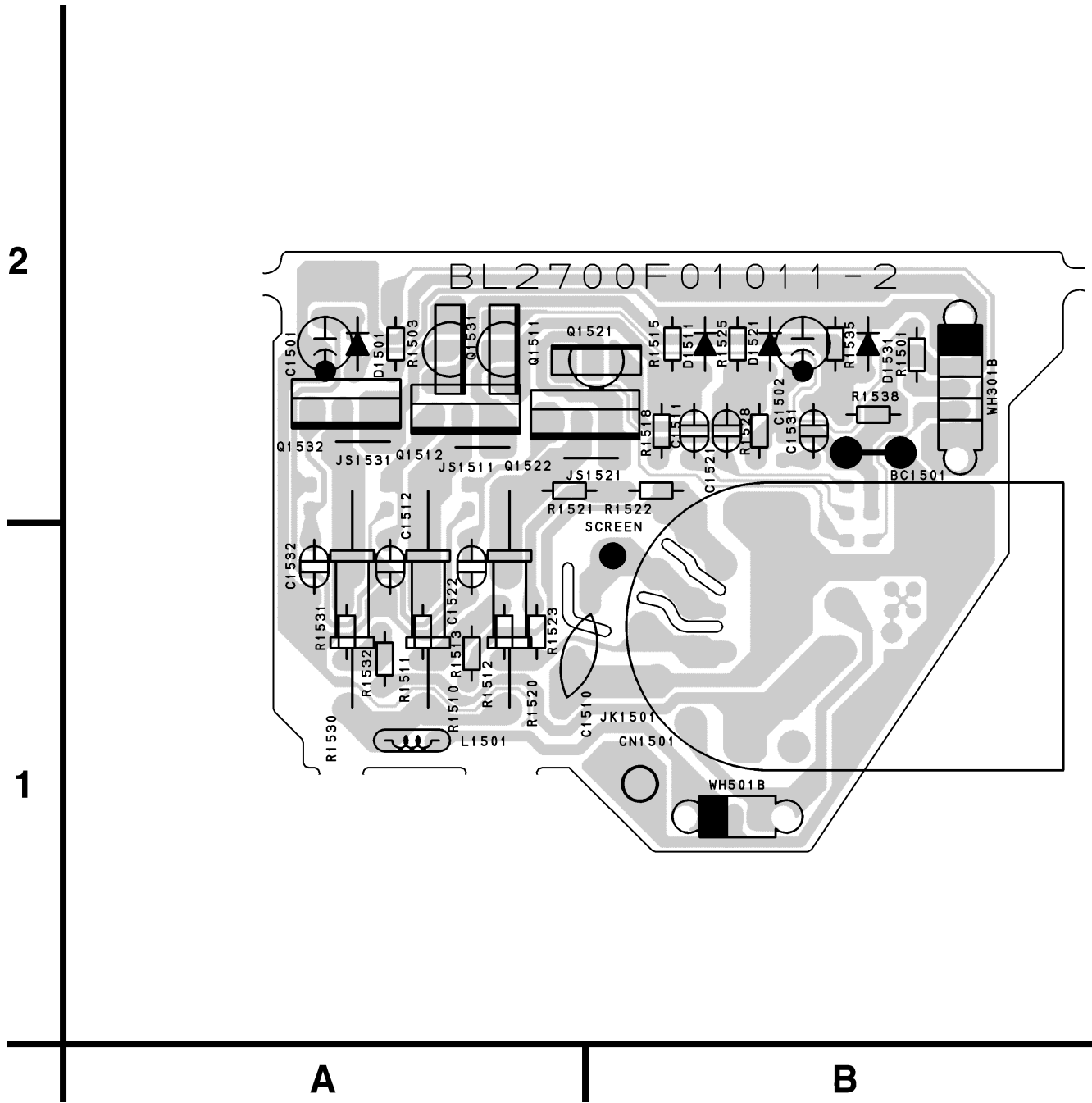

# WAVEFORMS

**WF1 ~ WF16 =** Waveforms to be observed at  
Waveform check points.  
(Shown in Schematic Diagram.)

**Input:** NTSC Color Bar Signal (with 1kHz Audio Signal)

**INITIAL POSITION:** Unplug unit from AC outlet for at least 5 minutes.  
reconnect to AC outlet and then turn power on.

(Brightness---Center Color---Center Tint --- Center Contrast---Approx 70%)

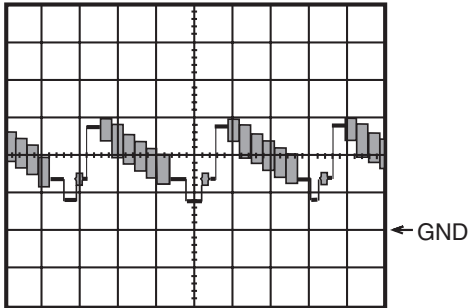

**WF1** 1DIV: 0.5V 20 $\mu$ sec  
IC 111 Pin 26

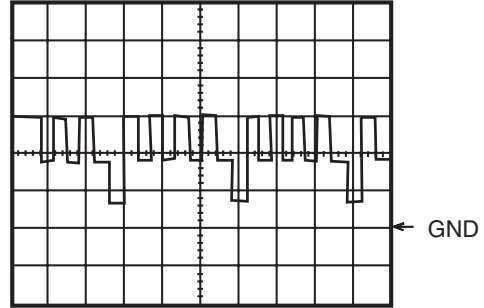

**WF5** 1DIV: 2V 20 $\mu$ sec  
Q 1531 Base

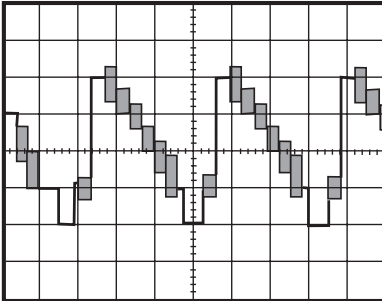

**WF2** 1DIV: 0.5V 20 $\mu$ sec  
IC 111 Pin 14

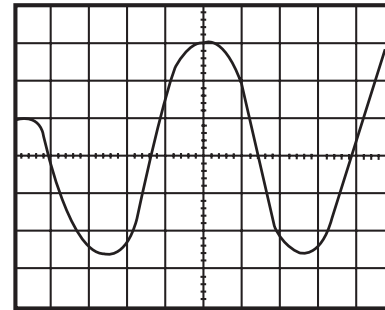

**WF6** 1DIV: 0.2V 20msec  
IC 801 Pin 3

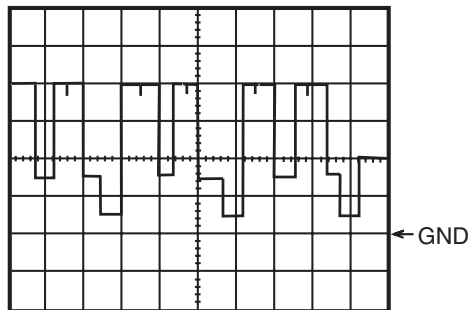

**WF3** 1DIV: 2V 20 $\mu$ sec  
Q1511 Base

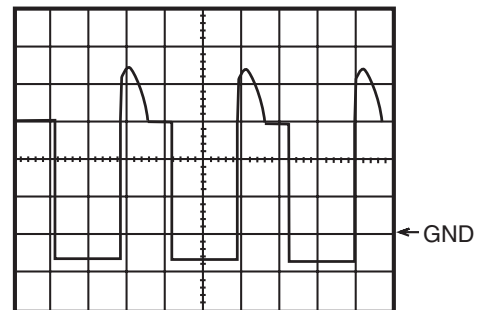

**WF7** 1DIV: 10V 20 $\mu$ sec  
Q 572 Collector

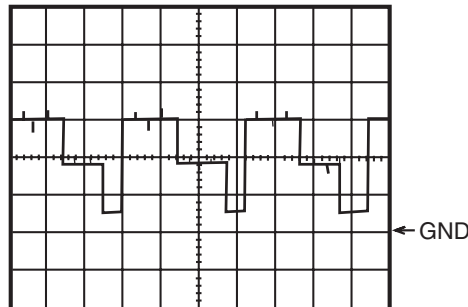

**WF4** 1DIV: 2V 20 $\mu$ sec  
Q 1521 Base

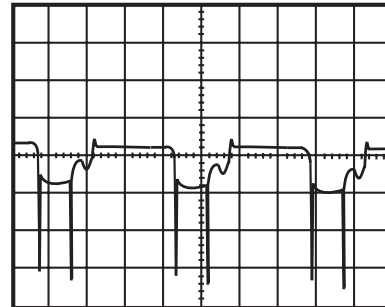

**WF8** 1DIV: 5V 20 $\mu$ sec  
Q 571 Base

**WF1 ~ WF16 =** Waveforms to be observed at  
Waveform check points.  
(Shown in Schematic Diagram.)

**Input:** NTSC Color Bar Signal (with 1kHz Audio Signal)

**INITIAL POSITION:** Unplug unit from AC outlet for at least 5 minutes.  
reconnect to AC outlet and then turn power on.

(Brightness---Center Color---Center Tint --- Center Contrast---Approx 70%)

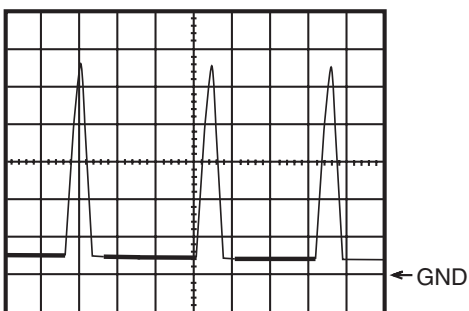

**WF9** 1DIV: 200V 20 $\mu$ sec  
CN 571 Pin 1

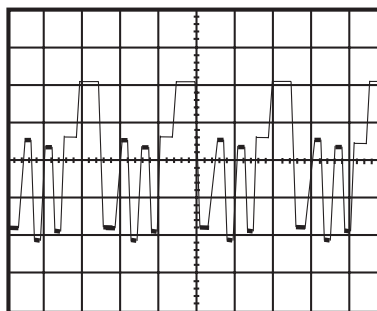

**WF13** 1DIV: 20V 20 $\mu$ sec  
Q 1531 Collector

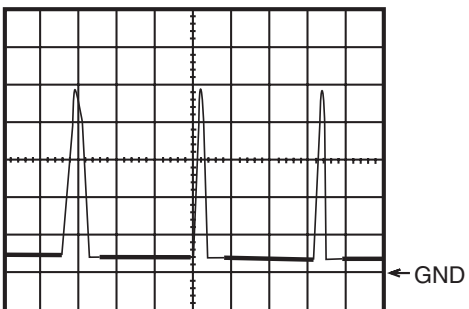

**WF10** 1DIV: 5V 20 $\mu$ sec  
WH501A Pin 3

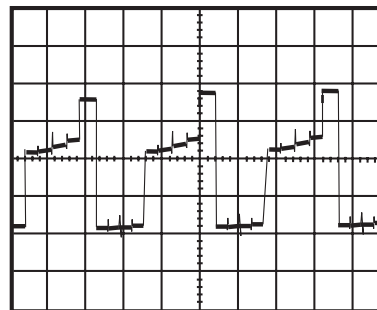

**WF14** 1DIV: 20V 20 $\mu$ sec  
Q 1521 Collector

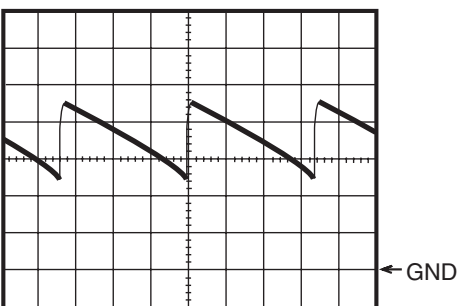

**WF11** 1DIV: 1V 5msec  
IC 551 Pin 7

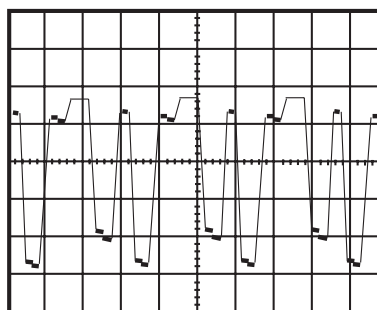

**WF15** 1DIV: 20V 20 $\mu$ sec  
Q 1511 Collector

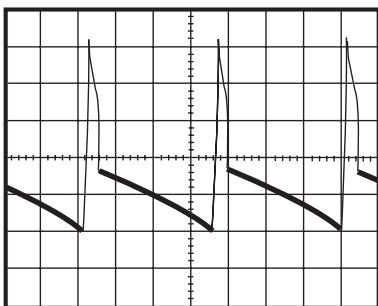

**WF12** 1DIV: 10V 5msec  
CN 571 Pin 4

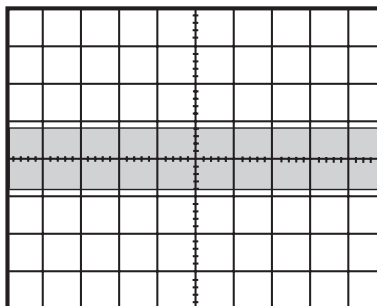

**WF16** 1DIV: 0.2V 20 $\mu$ sec  
TU 11 Pin 8

# WIRING DIAGRAM

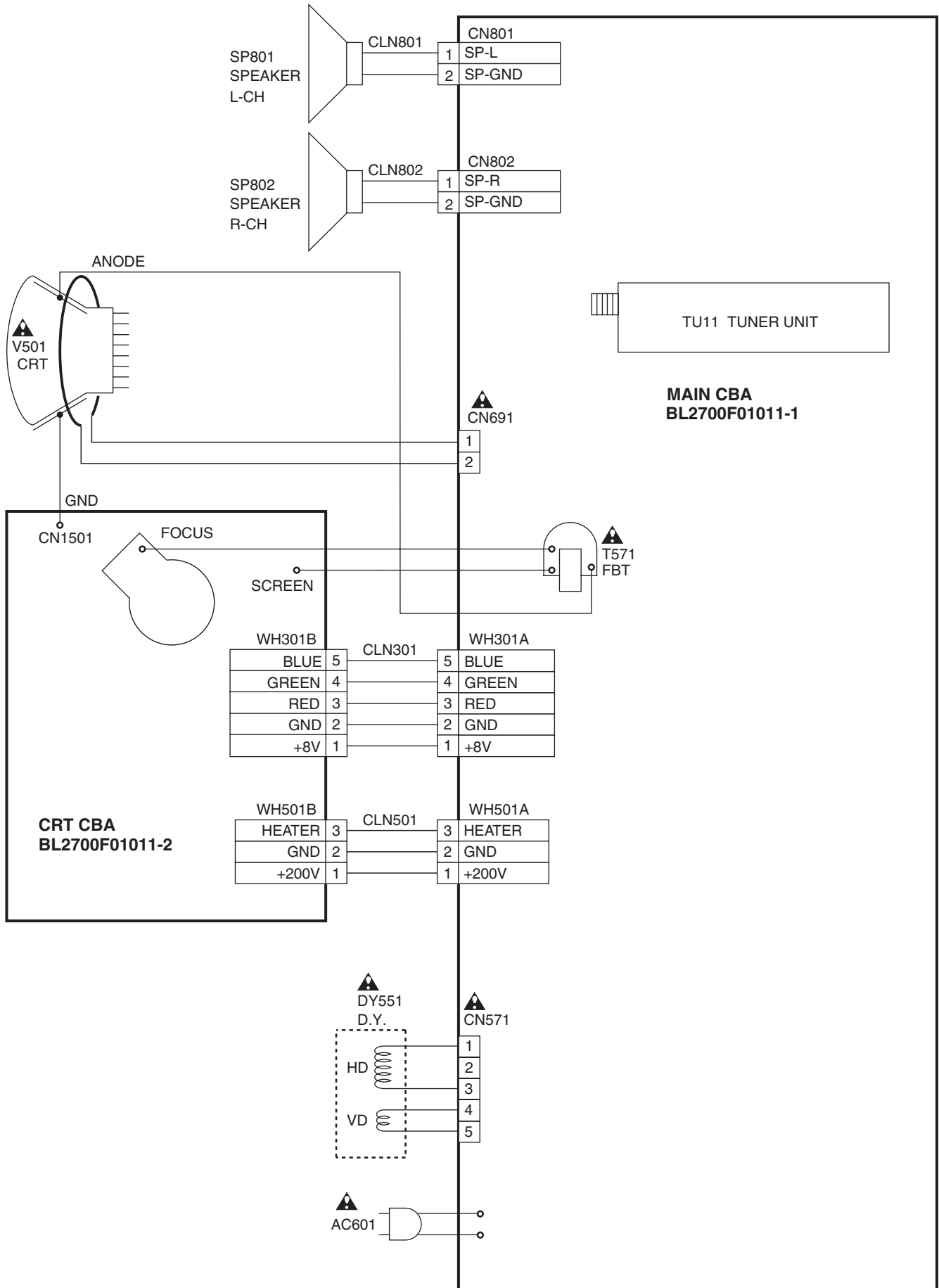

# IC PIN FUNCTIONS

## IC111 (TV Micro Controller)

Pin No.	Signal Name	Function
1	CNVSS	GND
2	N.U.	Not Used
3	N.U.	Not Used
4	N.U.	Not Used
5	GND	GND
6	VCC	ALL +5V
7	N.U.	(GND)
8	FILT	FILT
9	HLF	Filter for CCD
10	VHOLD	VHOLD
11	CVIN	Input for Video Signal
12	RESET	RESET
13	MCU RESET OUT	RESET Signal Output
14	Y-SW OUT	Composite Signal Output
15	GND	GND
16	3.58 X'TAL	3.58MHz Crystal
17	C-APC	CHROMINANCE APC
18	MCU 5.7REG OUT	Micro controller Control Voltage Output
19	N.U.	Not Used
20	N.U.	Not Used
21	N.U.	Not Used
22	VCC	VCC
23	N.U.	(GND)
24	CVBS IN2	Composite Signal Input 2
25	N.U.	Not Used
26	CVBS IN1	Composite Signal Input 1
27	N.U.	Not Used
28	5.7V REG OUT	5.7V Output
29	N.U.	Not Used
30	N.U.	Not Used
31	V REG VCC	DC 8.7V Input
32	FSC OUT	Clock Output 3.58MHz
33	N.U.	Not Used
34	N.U.	Not Used

Pin No.	Signal Name	Function
35	N.U.	Not Used
36	N.U.	Not Used
37	V RAMP F/B	V Ramp Feed Back
38	V RAMP OUT	Vertical Output
39	V RAMP CAP	V Ramp OSC Capacitor
40	8.7 VREG OUT	DC 8.7V Output
41	N.U.	Not Used
42	H VCO F/B	H Vco Feed Back
43	AFC FILT	Horizontal AFC Filter
44	GND	GND
45	FBP IN	Flyback Pulse Input
46	H-OUT	H Pulse Output
47	VCC	Vcc
48	VCC	Vcc
49	VCC	Vcc
50	R OUT	Red Output
51	G OUT	Green Output
52	B OUT	Blue Output
53	ACL	IB-Input
54	N.U.	Not Used
55	N.U.	Not Used
56	SDA	I2C-BUS Controller Interface (Data)
57	A-MUTE	Audio Mute
58	SCL	I2C-BUS Controller Interface (Clock)
59	N.U.	(GND)
60	N.U.	Not Used
61	N.U.	Not Used
62	VOLUME	Volume
63	INPUT0	Input Select 0
64	N.U.	Not Used
65	N.U.	Not Used
66	KEY-IN 1	Key Input 1 (Main)
67	PROTECT-2	Power Supply Protection
68	PROTECT-1	Power Supply Protection
69	KEY-IN 2	Key Input 2 (Main)
70	RCV-IN	Input For Remote Control

<b>Pin No.</b>	<b>Signal Name</b>	<b>Function</b>
71	MONO-OUT	MONO-OUT
72	I2C OPEN	White Balance Adjustment Judgement
73	AFT-IN	AFT Voltage Input
74	DG-ON-H	Degaussing Coil Control
75	AGC	AGC Voltage Input
76	PROTECT-3	Power Supply Protection
77	N.U.	Not Used
78	N.U.	Not Used
79	P-ON-H	Output for P-ON-H
80	N.U.	Not Used



# EXPLODED VIEWS

## Cabinet

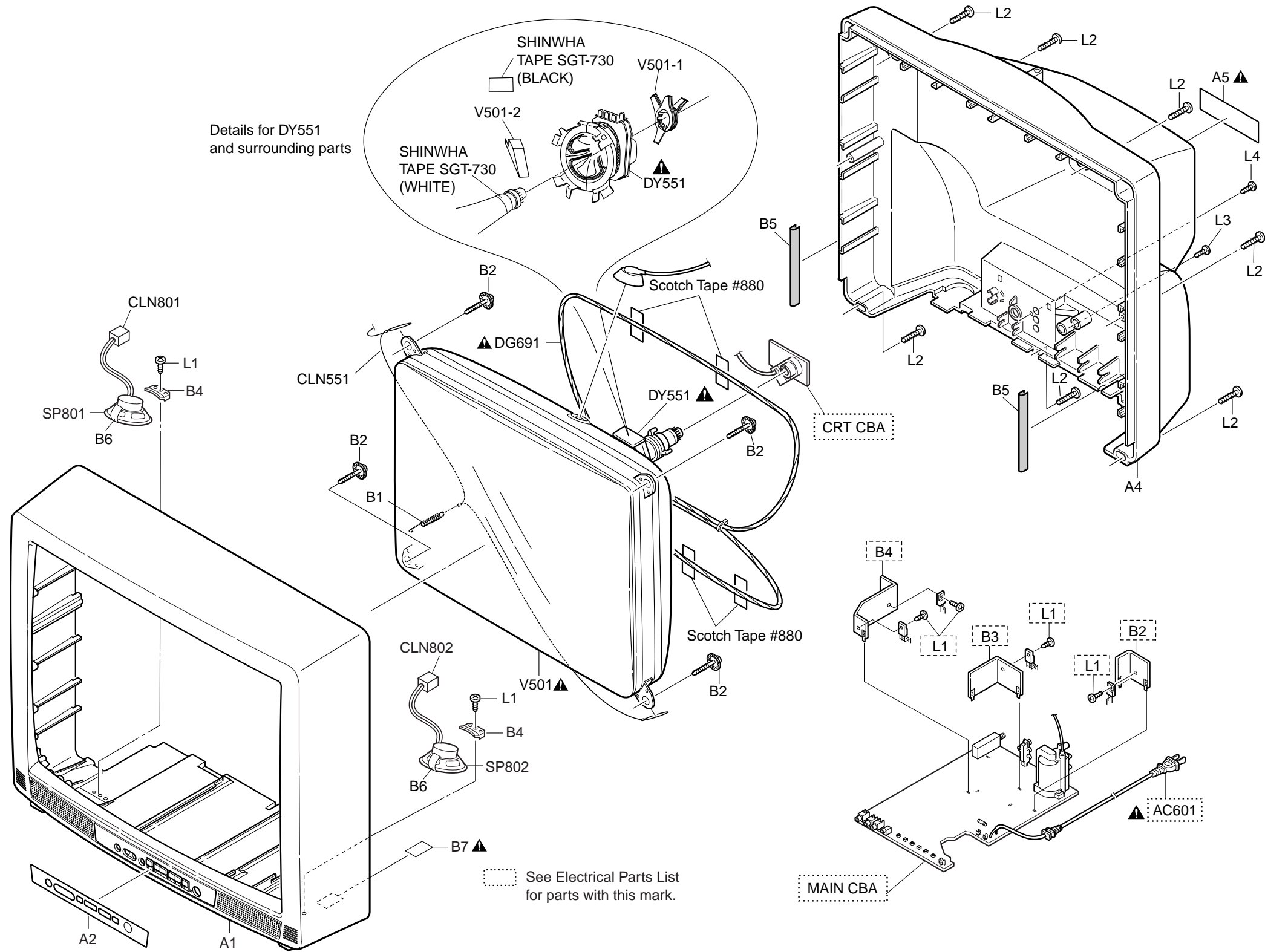

# Packing

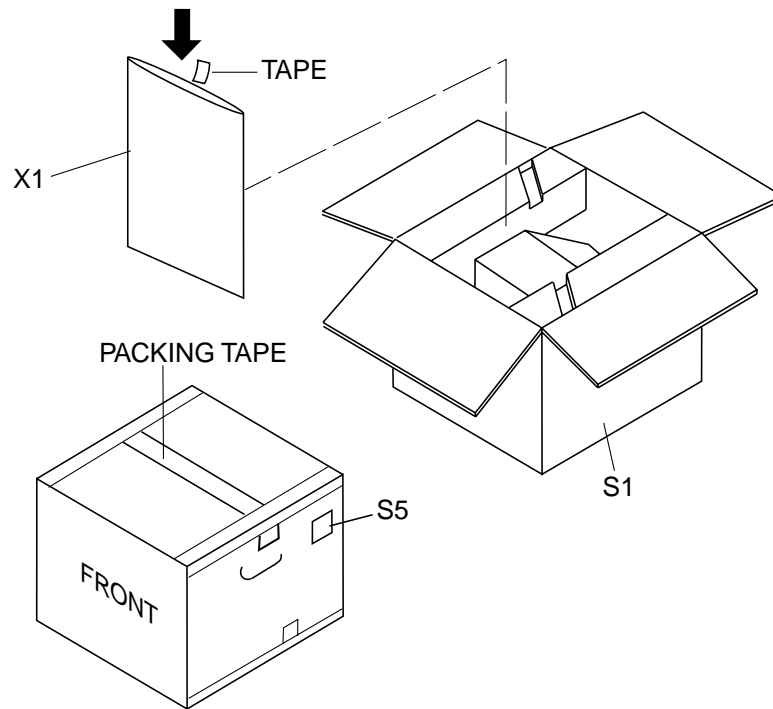
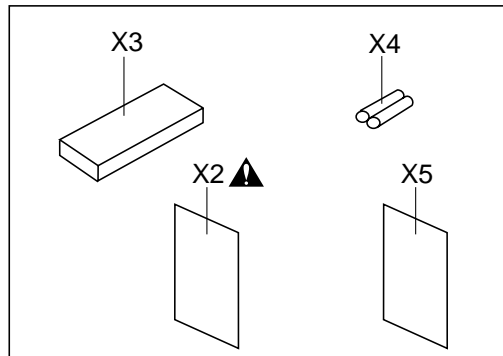
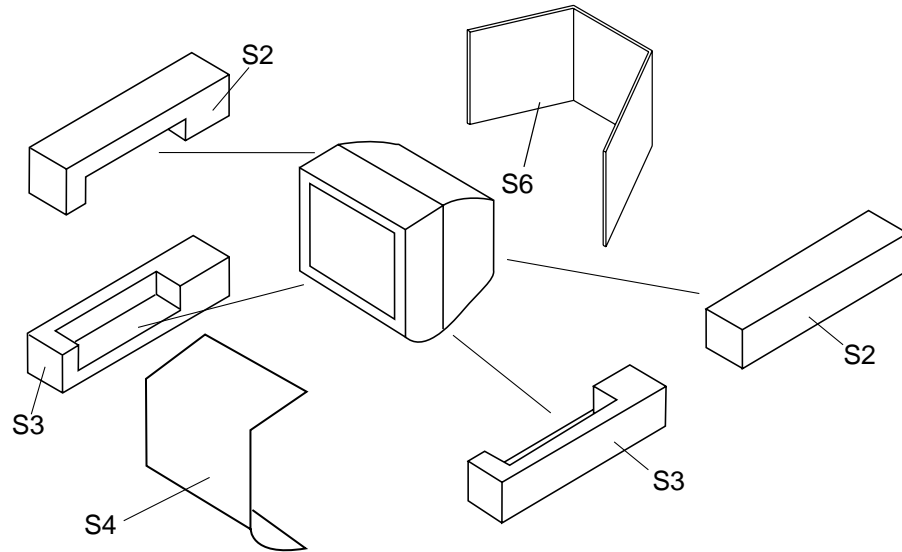

# MECHANICAL PARTS LIST

**PRODUCT SAFETY NOTE:** Products marked with a **▲** have special characteristics important to safety. Before replacing any of these components, read carefully the product safety notice in this service manual. Don't degrade the safety of the product through improper servicing.

**NOTE:**

Parts that are not assigned part numbers (-----) are not available.

### Comparison Chart of Models and Marks

Model	Mark
6427TE	A
SST4274	B

Ref. No.	Mark	Description	Part No.
A1	A	FRONT CABINET L2700UA	0EM000827
A1	B	FRONT CABINET L2702UC	0EM101436
A2	A	CONTROL PLATE L2701UB	0EM302050
A2	B	CONTROL PLATE L2702UC	0EM302036
A4		REAR CABINET L2705UF	0EM101432
A5▲	A	RATING LABEL L2701UB	-----
A5▲	B	RATING LABEL L2702UC	-----
B1		SPRING TENSION B0080B0:EM40808	26WH006
B2		SCREW M7 CRT(D22) T7205UF	0EM406573
B4		SPEAKER HOLDER L1200UA	0EM405691
B5		CLOTH L9800UA:95X15XT:0.5	0EM405041
B6		CLOTH(10X30XT1.0) L9814UQ	0EM405137
B3▲		HOLDER DEGAUSS L1200UA	0EM405869
B7▲		LABEL CRITICAL PARTS WARNING B8007C3:EM41210	-----
CLN551		CRT GND WIRE CRT GND	WX1L1200-007
CLN801		WIRE ASSEMBLY SPEAKER WIRE(180MM)	WX1L9800-001
CLN802		WIRE ASSEMBLY WX1L2700-001	WX1L2700-001
DG691▲		DEGAUSSING COIL F-029 or	LLBH002TM029
▲		DEGAUSSING COIL AI-007-00	LLBH002ZA004
L1		SCREW, P-TIGHT 3X12 BIND HEAD+	GBMP3120
L2		SCREW, P-TIGHT 4X18 BIND HEAD +	GBMP4180
L3		SCREW TAPPING M4X14	DBU14140
L4		SCREW, P-TIGHT 3X10 BIND HEAD+	GBKP3100
SP801		SPEAKER S08N04	DSD0808XQ013
SP802		SPEAKER S08N04	DSD0808XQ013
<b>PACKING</b>			
S1	A	CARTON L2701UB	0EM408914
S1	B	CARTON L2702UC	0EM408851
S2		STYROFOAM TOP L6201UB	0EM000645
S3		STYROFOAM BOTTOM L6201UB	0EM000646
S4		SHEET SET PCEC:003502019816	0EM403887
S5	A	SERIAL NO. LABEL L2701UB	-----
S5	B	SERIAL NO. LABEL L2702UC	-----
S6		HOLD PAD L6201UB	0EM407287
<b>ACCESSORIES</b>			
X1		BAG POLYETHYLENE 235X365XT0.03	0EM408420

Ref. No.	Mark	Description	Part No.
X2▲	A	OWNER'S MANUAL L2701UB:ENGLISH/SPANISH	0EMN02377
X2▲	B	OWNER'S MANUAL L2702UC:ENGLISH/SPANISH	0EMN02357
X3	A	REMOTE CONTROL 130/ERC001/ N0108UD or	N0108UD
	A	REMOTE CONTROL 130/ERC001/ N0132UD	N0132UD
X3	B	REMOTE CONTROL NE121UD	NE121UD
X4		DRY BATTERY R6P UM3 or	XB0M451GH001
		DRY BATTERY R6P/2S or	XB0M451T0001
		DRY BATTERY(SUNRISE) R6SSE/2S or	XB0M451MS002
		DRY BATTERY R6P(AR)2PX or	XB0M451HU002
		DRY BATTERY R6P(AR)2P X ICI	XB0M451HU003
X5		SHEET RETURN STOP L6101UB	0EM407077
<b>Note:</b>			
1. V501 (CRT) HAS COUPLE OF SUBSTITUTIONAL PARTS AND EACH PARTS ALSO HAS MATCHING COMBINATION WITH DY551.			
PLEASE SEE TABLE 1 FOR DETAILS OF MATCHING COMBINATION.			
2. DY551 (DEFLECTION YOKE) HAS MATCHING COMBINATION WITH V501.			
PLEASE SEE TABLE 1 FOR DETAILS OF MATCHING COMBINATION.			
<b>CRT TYPE A</b>			
DY551▲		DEFLECTION YOKE ODY-C29029 or	LLBY00ZQS006
▲		DEFLECTION YOKE CDY-29029F	LLBY00ZQS012
V501▲		CRT A68KTB359X(B) or	TCRT190QS024
▲		CRT A68KTB359X(PB) or	TCRT190QS025
▲		CRT A68KTB259X2 or	TCRT190QS021
▲		CRT A68KTB259X(P)	TCRT190QS023
V501-1		PCM JH88DTA	XM04000BV010
V501-2		WEDGE FT-00110W or	XV10000T4001
		WEDGE DB25SR	XV10000D9001
<b>CRT TYPE B</b>			
DY551▲		DEFLECTION YOKE CDY-F2927H or	LLBY00ZQS014
▲		DEFLECTION YOKE DHF-2913FU(S)	LLBY00ZSM009
V501▲		CRT A68QBT892X	TCRT190SM028
V501-1		PCM JH88DTA	XM04000BV010
V501-2		WEDGE FT-00110W or	XV10000T4001
		WEDGE DB25SR	XV10000D9001
<b>CRT TYPE C</b>			
DY551▲		DEFLECTION YOKE 6150Z-1046A or	LLBY00ZGS008
▲		DEFLECTION YOKE KDY4UWE21X	LLBY00ZMS026
V501▲		CRT A68QBC230X	TCRT190GS043
V501-1		PCM JH88DTA	XM04000BV010
V501-2		WEDGE FT-00110W or	XV10000T4001
		WEDGE DB25SR	XV10000D9001

## Table 1 (V501 and DY551 Combination)

**Note 1:** Purity and Convergence Adjustments must be performed following CRT replacement. Refer to Electrical Adjustment Instructions.

**Note 2:** Please confirm CRT Type No. on the CRT Warning Label which is located on the CRT. Then See the Table 1 for V501 and DY551 combination chart. Please refer this CRT, Deflection Yoke combination chart for parts order.

V501: CRT Type No.	V501: CRT Part No.	DY551: Deflection Yoke Part No.
A68KTB359X(B)	TCRT190QS024	LLBY00ZQS006
		LLBY00ZQS012
A68KTB359X(PB)	TCRT190QS025	LLBY00ZQS006
		LLBY00ZQS012
A68KTB259X2	TCRT190QS021	LLBY00ZQS006
		LLBY00ZQS012
A68KTB259X(P)	TCRT190QS023	LLBY00ZQS006
		LLBY00ZQS012
A68QBT892X	TCRT190SM028	LLBY00ZQS014
		LLBY00ZSM009
A68QBC230X	TCRT190GS043	LLBY00ZGS008
		LLBY00ZMS026

## CRT Warning Label Location

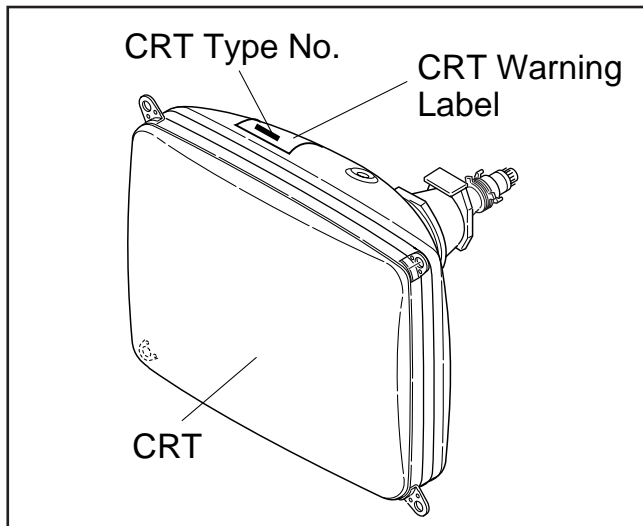

# ELECTRICAL PARTS LIST

**PRODUCT SAFETY NOTE:** Products marked with a  have special characteristics important to safety. Before replacing any of these components, read carefully the product safety notice in this service manual. Don't degrade the safety of the product through improper servicing.



**NOTES:**

- Parts that are not assigned part numbers (-----) are not available.
- Tolerance of Capacitors and Resistors are noted with the following symbols.

C.....±0.25%    D.....±0.5%    F.....±1%  
 G.....±2%    J.....±5%    K.....±10%  
 M.....±20%    N.....±30%    Z.....+80/-20%

## MMA CBA

Ref. No.	Description	Part No.
	MMA-423 CBA Consists of the following	0ESA05768
	MAIN CBA	-----
	CRT CBA	-----

T571 	FLYBACK TRANSFORMER JF0501-2167 or	LTF00CPXB030
	FLYBACK TRANS BW03081	LTF00CP1H001

## MAIN CBA

Ref. No.	Description	Part No.
	MAIN CBA Consists of the following	-----
<b>CAPACITORS</b>		
C11	CERAMIC CAP.(AX) F Z 0.01µF/25V	CDA1EZT0F103
C12	ELECTROLYTIC CAP. 100µF/10V M or ELECTROLYTIC CAP. 100µF/10V M	CE1AMASTL101 CE1AMASDL101
C13	ELECTROLYTIC CAP. 4.7µF/50V M or ELECTROLYTIC CAP. 4.7µF/50V M	CE1JMASTL4R7 CE1JMASDL4R7
C14	CHIP CERAMIC CAP. B K 0.01µF/50V	CHD1JKB0B103
C31	ELECTROLYTIC CAP. 100µF/10V M or ELECTROLYTIC CAP. 100µF/10V M	CE1AMASTL101 CE1AMASDL101
C34	ELECTROLYTIC CAP. 0.47µF/50V M or ELECTROLYTIC CAP. 0.47µF/50V M	CE1JMASTLR47 CE1JMASDLR47
C35	CHIP CERAMIC CAP. CH J 47pF/50V	CHD1JJBCH470
C36	CERAMIC CAP.(AX) B K 1000pF/50V	CCA1JKT0B102
C37	ELECTROLYTIC CAP. 1µF/50V M or ELECTROLYTIC CAP. 1µF/50V M or ELECTROLYTIC CAP. 1µF/50V M or	CE1JMASTL1R0 CE1JMASDL1R0 CE1JMASDL010
C38	CERAMIC CAP.(AX) SL J 47pF/50V	CCA1JTSLS470
C49	ELECTROLYTIC CAP. 4.7µF/50V M or	CE1JMASTL4R7

Ref. No.	Description	Part No.
	ELECTROLYTIC CAP. 4.7µF/50V M	CE1JMASDL4R7
C51	CERAMIC CAP.(AX) B K 1000pF/50V	CCA1JKT0B102
C52	CHIP CERAMIC CAP F Z 0.01µF/25V	CHD1EZB0F103
C53	ELECTROLYTIC CAP. 100µF/10V M or ELECTROLYTIC CAP. 100µF/10V M	CE1AMASTL101 CE1AMASDL101
C54	CHIP CERAMIC CAP. B K 1000pF/50V	CHD1JKB0B102
C55	CHIP CERAMIC CAP F Z 0.01µF/25V	CHD1EZB0F103
C56	PCB JUMPER D0.6-P5.0	JW5.0T
C57	FILM CAP.(P) 0.047µF/50V J or FILM CAP.(P) 0.047µF/50V J	CMA1JJS00473 CA1J473MS029
C58	FILM CAP.(P) 0.033µF/50V J or FILM CAP.(P) 0.033µF/50V J	CMA1JJS00333 CA1J333MS029
C104	ELECTROLYTIC CAP. 10µF/50V M or ELECTROLYTIC CAP. 10µF/50V M	CE1JMASTL100 CE1JMASDL100
C111	ELECTROLYTIC CAP. 47µF/16V M or ELECTROLYTIC CAP. 47µF/16V M	CE1CMASL470 CE1CMASDL470
C112	ELECTROLYTIC CAP. 4.7µF/50V M or ELECTROLYTIC CAP. 4.7µF/50V M	CE1JMASTL4R7 CE1JMASDL4R7
C113	CHIP CERAMIC CAP. F Z 0.1µF/25V	CHD1EZB0F104
C114	FILM CAP.(P) 0.001µF/50V J or FILM CAP.(P) 0.001µF/50V J	CMA1JJS00102 CA1J102MS029
C115	ELECTROLYTIC CAP. 0.1µF/50V M or ELECTROLYTIC CAP. 0.1µF/50V M or ELECTROLYTIC CAP. 0.1µF/50V M	CE1JMASTLR10 CE1JMASDLR10 CE1JMASDL0R1
C116	CERAMIC CAP.(AX) B K 220pF/50V	CCA1JKT0B221
C117	CERAMIC CAP.(AX) Y K 0.01µF/16V	CDA1CKT0Y103
C120	ELECTROLYTIC CAP. 100µF/10V M or ELECTROLYTIC CAP. 100µF/10V M	CE1AMASTL101 CE1AMASDL101
C122	ELECTROLYTIC CAP. 100µF/10V M or ELECTROLYTIC CAP. 100µF/10V M	CE1AMASTL101 CE1AMASDL101
C132	CERAMIC CAP.(AX) F Z 0.1µF/50V or CERAMIC CAP.(AX) F Z 0.1µF/50V	CA1J104TU014 CCA1JZT0F104
C133	CERAMIC CAP.(AX) F Z 0.01µF/25V	CDA1EZT0F103
C150	CHIP CERAMIC CAP. F Z 0.1µF/25V	CHD1EZB0F104
C151	CERAMIC CAP.(AX) B K 220pF/50V	CCA1JKT0B221
C152	CERAMIC CAP.(AX) B K 220pF/50V	CCA1JKT0B221
C301	CHIP CERAMIC CAP. CH J 120pF/50V	CHD1JJBCH121
C302	ELECTROLYTIC CAP. 1µF/50V M or ELECTROLYTIC CAP. 1µF/50V M or ELECTROLYTIC CAP. 1µF/50V M	CE1JMASTL1R0 CE1JMASDL1R0 CE1JMASDL010
C303	CERAMIC CAP.(AX) B K 0.015µF/50V	CA1J153TU011
C306	ELECTROLYTIC CAP. 100µF/10V M or ELECTROLYTIC CAP. 100µF/10V M	CE1AMASTL101 CE1AMASDL101
C309	ELECTROLYTIC CAP. 0.1µF/50V M or ELECTROLYTIC CAP. 0.1µF/50V M or ELECTROLYTIC CAP. 0.1µF/50V M	CE1JMASTLR10 CE1JMASDLR10 CE1JMASDL0R1
C322	ELECTROLYTIC CAP. 0.47µF/50V M or ELECTROLYTIC CAP. 0.47µF/50V M	CE1JMASTLR47 CE1JMASDLR47
C324	ELECTROLYTIC CAP. 10µF/50V M or ELECTROLYTIC CAP. 10µF/50V M	CE1JMASTL100 CE1JMASDL100
C325	CERAMIC CAP.(AX) SL J 12pF/50V	CCA1JTSLS120
C328	ELECTROLYTIC CAP. 10µF/50V M or ELECTROLYTIC CAP. 10µF/50V M	CE1JMASTL100 CE1JMASDL100
C329	CERAMIC CAP.(AX) F Z 0.01µF/25V	CDA1EZT0F103
C330	STACKED FILM CAP. 0.47µF/50V J or TF CAP. 0.47µF/50V J or	CMA1JJS00474 CT1J474MS045

Ref. No.	Description	Part No.
	TF CAP. 0.47μF/50V J	CT1J474MS010
C341	CHIP CERAMIC CAP. B K 0.01μF/50V	CHD1JKB0B103
C342	ELECTROLYTIC CAP. 1μF/50V M or	CE1JMASTL1R0
	ELECTROLYTIC CAP. 1μF/50V M or	CE1JMASDL1R0
	ELECTROLYTIC CAP. 1μF/50V M or	CE1JMASDL010
	ELECTROLYTIC CAP. 1μF/50V M	CE1JMASTL010
C343	CHIP CERAMIC CAP. B K 0.01μF/50V	CHD1JKB0B103
C345	ELECTROLYTIC CAP. 1000μF/10V M or	CE1AMASTL102
	ELECTROLYTIC CAP. 1000μF/10V M	CE1AMASDL102
C353	ELECTROLYTIC CAP. 1μF/50V M or	CE1JMASTL1R0
	ELECTROLYTIC CAP. 1μF/50V M or	CE1JMASDL1R0
	ELECTROLYTIC CAP. 1μF/50V M or	CE1JMASDL010
	ELECTROLYTIC CAP. 1μF/50V M	CE1JMASTL010
C401	ELECTROLYTIC CAP. 3.3μF/50V M or	CE1JMASTL3R3
	ELECTROLYTIC CAP. 3.3μF/50V M	CE1JMASDL3R3
C402	ELECTROLYTIC CAP. 3.3μF/50V M or	CE1JMASTL3R3
	ELECTROLYTIC CAP. 3.3μF/50V M	CE1JMASDL3R3
C403	CERAMIC CAP.(AX) F Z 0.1μF/50V or	CA1J104TU014
	CERAMIC CAP.(AX) F Z 0.1μF/50V	CCA1JZT0F104
C404	CERAMIC CAP.(AX) B K 0.022μF/50V	CA1J223TU011
C405	CHIP CERAMIC CAP. F Z 0.1μF/25V	CHD1EZB0F104
C406	CHIP CERAMIC CAP. B K 0.033μF/25V	CHD1EKB0B333
C411	ELECTROLYTIC CAP. 4.7μF/50V M or	CE1JMASTL4R7
	ELECTROLYTIC CAP. 4.7μF/50V M	CE1JMASDL4R7
C413	ELECTROLYTIC CAP. 100μF/10V M or	CE1AMASTL101
	ELECTROLYTIC CAP. 100μF/10V M	CE1AMASDL101
C414	ELECTROLYTIC CAP. 2.2μF/50V M or	CE1JMASTL2R2
	ELECTROLYTIC CAP. 2.2μF/50V M	CE1JMASDL2R2
C415	CHIP CERAMIC CAP. CH J 150pF/50V	CHD1JJBCH151
C416	CHIP CERAMIC CAP. CH J 150pF/50V	CHD1JJBCH151
C417	ELECTROLYTIC CAP. 2.2μF/50V M or	CE1JMASTL2R2
	ELECTROLYTIC CAP. 2.2μF/50V M	CE1JMASDL2R2
C421	ELECTROLYTIC CAP. 4.7μF/50V M or	CE1JMASTL4R7
	ELECTROLYTIC CAP. 4.7μF/50V M	CE1JMASDL4R7
C422	ELECTROLYTIC CAP. 0.47μF/50V M or	CE1JMASTLR47
	ELECTROLYTIC CAP. 0.47μF/50V M	CE1JMASDLR47
C423	CHIP CERAMIC CAP. B K 4700pF/50V	CHD1JKB0B472
C426	ELECTROLYTIC CAP. 4.7μF/50V M or	CE1JMASTL4R7
	ELECTROLYTIC CAP. 4.7μF/50V M	CE1JMASDL4R7
C427	ELECTROLYTIC CAP. 0.47μF/50V M or	CE1JMASTLR47
	ELECTROLYTIC CAP. 0.47μF/50V M	CE1JMASDLR47
C428	CERAMIC CAP.(AX) X K 4700pF/16V	CDA1CKT0X472
C441	ELECTROLYTIC CAP. 10μF/50V M or	CE1JMASTL100
	ELECTROLYTIC CAP. 10μF/50V M	CE1JMASDL100
C442	ELECTROLYTIC CAP. 2.2μF/50V M or	CE1JMASTL2R2
	ELECTROLYTIC CAP. 2.2μF/50V M	CE1JMASDL2R2
C444	ELECTROLYTIC CAP. 0.33μF/50V M or	CE1JMASTLR33
	ELECTROLYTIC CAP. 0.33μF/50V M	CE1JMASDLR33
C445	FILM CAP.(P) 0.1μF/50V J or	CMA1JJS00104
	FILM CAP.(P) 0.1μF/50V J	CA1J104MS029
C446	FILM CAP.(P) 0.1μF/50V J or	CMA1JJS00104
	FILM CAP.(P) 0.1μF/50V J	CA1J104MS029
C448	ELECTROLYTIC CAP. 2.2μF/50V M or	CE1JMASTL2R2
	ELECTROLYTIC CAP. 2.2μF/50V M	CE1JMASDL2R2
C501	FILM CAP.(P) 0.1μF/100V J or	CMA2AJS00104
	FILM CAP.(P) 0.1μF/100V J TV or	CMB2AJS00104
	FILM CAP.(P) 0.1μF/100V J	CA2A104MS029
C502	CERAMIC CAP.(AX) B K 1000pF/50V	CCA1JKT0B102
C503	ELECTROLYTIC CAP. 47μF/35V M or	CE1GMASSTL470
	ELECTROLYTIC CAP. 47μF/35V M	CE1GMASDL470
C504	ELECTROLYTIC CAP. 1.5μF/50V M LL or	CE1JMASLL1R5

Ref. No.	Description	Part No.
	ELECTROLYTIC CAP. 1.5μF/50V LL	CE1JMASLL1R5
C505	ELECTROLYTIC CAP. 1000μF/35V M or	CE1GMZNTL102
	ELECTROLYTIC CAP. 1000μF/35V M or	CE1GMZADL102
	ELECTROLYTIC CAP. 1000μF/35V M	CE1GMZNDL102
C506	ELECTROLYTIC CAP. 470μF/35V M(VR) or	CE1GMZNTL471
	ELECTROLYTIC CAP. 470μF/35V M or	CE1GMZADL471
	ELECTROLYTIC CAP. 470μF/35V M	CE1GMZNDL471
C511	ELECTROLYTIC CAP. 100μF/10V M or	CE1AMASTL101
	ELECTROLYTIC CAP. 100μF/10V M	CE1AMASDL101
C520▲	ELECTROLYTIC CAP. 10μF/50V M or	CE1JMASTL100
▲	ELECTROLYTIC CAP. 10μF/50V M	CE1JMASDL100
C551	PCB JUMPER D0.6-P7.5	JW7.5T
C555	METALIZED PLYESTER CAP. 1μF/100V J or	CT2A105MS065
	METALLIZED POLYESTER CAP 1μF/100 J	CT2A105HJE25
C556	FILM CAP.(P) 0.1μF/50V J or	CMA1JJS00104
	FILM CAP.(P) 0.1μF/50V J	CA1J104MS029
C561	ELECTROLYTIC CAP. 47μF/35V M or	CE1GMASSTL470
	ELECTROLYTIC CAP. 47μF/35V M	CE1GMASDL470
C562	ELECTROLYTIC CAP. 470μF/10V M or	CE1AMASTL471
	ELECTROLYTIC CAP. 470μF/10V M	CE1AMASDL471
C565	FILM CAP.(P) 0.1μF/50V J or	CMA1JJS00104
	FILM CAP.(P) 0.1μF/50V J	CA1J104MS029
C567▲	PP CAP. 0.0033μF/1.6KV J or	CA3C332VC010
▲	PP CAP. 0.0033μF/1.6KV J or	CT3C332MS039
▲	PP CAP. 0.0033μF/1.6KV J or	CBH3CJQ00332
▲	METALLIZED FILM CAP. 0.0033μF/1.6KV J or	CT3C332F7002
▲	METALLIZED FILM CAP. 0.0033μF/1.6KV J	CT3C332F7004
C571▲	PP. CAP. 0.33μF/200V J or	CA2D334VC012
▲	PP CAP. 0.33μF/250V J or	CT2E334MS041
▲	METALLIZED FILM CAP. 0.33μF/200V J or	CT2D334F7001
▲	METALLIZED FILM CAP. 0.33μF/200V J	CT2D334F7003
C572▲	PP. CAP. 0.18μF/200V J or	CA2D184VC012
▲	PP CAP. 0.18μF/250V J or	CT2E184MS041
▲	METALLIZED FILM CAP. 0.18μF/200V J or	CT2D184F7001
▲	METALLIZED FILM CAP. 0.18μF/200V J	CT2D184F7003
C574▲	ELECTROLYTIC CAP 10μF/250V M or	CE2EMZNDL100
▲	ELECTROLYTIC CAP. 10μF/250V M	CE2EMZPDL100
C577	ELECTROLYTIC CAP. 47μF/35V M or	CE1GMASSTL470
	ELECTROLYTIC CAP. 47μF/35V M	CE1GMASDL470
C578	FILM CAP.(P) 0.01μF/50V J or	CMA1JJS00103
	FILM CAP.(P) 0.01μF/50V J	CA1J103MS029
C580▲	PP CAP. 0.015μF/1.6KV J or	CA3C153VC010
▲	PP CAP. 0.015μF/1.6KV J or	CT3C153MS039
▲	PP CAP. 0.015μF/1.6KV J or	CBH3CJQ00153
▲	METALLIZED FILM CAP. 0.015μF/1.6KV J	CT3C153F7004
C582▲	PP. CAP. 0.022μF/200V J or	CA2D223VC013
▲	PP. CAP. 0.022μF/200V K or	CBP2DKD00223
▲	METALLIZED FILM CAP. 0.022μF/200V J	CT2D223F7002
C584▲	ELECTROLYTIC CAP. 0.47μF/160V M or	CE2CMASSTLR47
▲	ELECTROLYTIC CAP. 0.47μF/160V M	CE2CMASDLR47
C588▲	ELECTROLYTIC CAP. 100μF/160V M or	CE2CMZPTL101
▲	ELECTROLYTIC CAP. 100μF/160V M	CE2CMZNDL101
C594▲	ELECTROLYTIC CAP. 10μF/50V M or	CE1JMASTL100
▲	ELECTROLYTIC CAP. 10μF/50V M	CE1JMASDL100
C596	CERAMIC CAP. B K 100pF/500V	CCD2JKS0B101
C601▲	METALLIZED FILM CAP. 0.1μF/250V or	CT2E104MS037
▲	FILM CAP.(MP) 0.1μF/250V K or	CT2E104DC011
▲	METALLIZED FILM CAP. 0.1μF/275V K	CT2E104HJE06
C603	CERAMIC CAP.(AX) B K 470pF/50V	CCA1JKT0B471
C605	CERAMIC CAP. F Z 0.01μF/500V or	CCD2JZP0F103
	CERAMIC CAP. 0.01μF/AC250V or	CCD2EZA0F103

Ref. No.	Description	Part No.
	CERAMIC CAP. E Z 0.01 $\mu$ F/500V	CCD2JZP0E103
C606	CERAMIC CAP. F Z 0.01 $\mu$ F/500V or	CCD2JZP0F103
	CERAMIC CAP. 0.01 $\mu$ F/AC250V or	CCD2EZA0F103
	CERAMIC CAP. E Z 0.01 $\mu$ F/500V	CCD2JZP0E103
C609	CERAMIC CAP. LB 1000pF/2KV or	CA3D102KG004
	CERAMIC CAP. BN 1000pF/2KV or	CCD3DKA0B102
	CERAMIC CAP. 1000pF/2KV or	CA3D102PAN04
	CERAMIC CAP. RB 1000pF/2KV	CA3D102TE006
C610▲	ELECTROLYTIC CAP. 470 $\mu$ F/200V or	CA2D471NC013
▲	ELECTROLYTIC CAP. 470 $\mu$ F/200V M	CE2DMZNDL471
C611	FILM CAP.(P) 0.0056 $\mu$ F/50V J or	CMA1JJS00562
	FILM CAP.(P) 0.0056 $\mu$ F/50V J	CA1J562MS029
C613	FILM CAP.(P) 0.056 $\mu$ F/50V J or	CMA1JJS00563
	FILM CAP.(P) 0.056 $\mu$ F/50V J	CA1J563MS029
C614	CERAMIC CAP.(AX) X K 2700pF/16V	CDA1CKT0X272
C616	FILM CAP.(P) 0.1 $\mu$ F/50V J or	CMA1JJS00104
	FILM CAP.(P) 0.1 $\mu$ F/50V J	CA1J104MS029
C618	FILM CAP.(P) 0.1 $\mu$ F/50V J or	CMA1JJS00104
	FILM CAP.(P) 0.1 $\mu$ F/50V J	CA1J104MS029
<b>If C642 is 0.01<math>\mu</math>F, then C643 is 0.01<math>\mu</math>F.</b>		
C642▲	SAFETY CAP. 10000pF/250V or	CCG2EMA0F103
▲	SAFETY CAP. F M 0.01 $\mu$ F/250V or	CCG2EMP0F103
▲	CERAMIC CAP. 0.01 $\mu$ F F CS	CCG2HMN0F103
C643▲	SAFETY CAP. 10000pF/250V or	CCG2EMA0F103
▲	SAFETY CAP. F M 0.01 $\mu$ F/250V or	CCG2EMP0F103
▲	CERAMIC CAP. 0.01 $\mu$ F F CS	CCG2HMN0F103
<b>If C643 is 4700pF, then JS642(PCB JUMPER) is used.</b>		
C643▲	SAFETY CAP. 4700pF/250V KX	CA2E472MR050
JS642	PCB JUMPER D0.6-P10.0	JW10.0T
C651	CERAMIC CAP. LB 560pF/2KV or	CA3D561KG004
	CERAMIC CAP. BN 560pF/2KV or	CCD3DKA0B561
	CERAMIC CAP. 560pF/2KV or	CA3D561PAN04
	CERAMIC CAP. RB 560pF/2KV	CA3D561TE006
C654▲	ELECTROLYTIC CAP. 1 $\mu$ F/50V M or	CE1JMASTL1R0
▲	ELECTROLYTIC CAP. 1 $\mu$ F/50V M or	CE1JMASDL1R0
▲	ELECTROLYTIC CAP. 1 $\mu$ F/50V M or	CE1JMASDL010
▲	ELECTROLYTIC CAP. 1 $\mu$ F/50V M	CE1JMASTL010
C656▲	ELECTROLYTIC CAP. 100 $\mu$ F/160V M or	CE2CMZPTL101
▲	ELECTROLYTIC CAP. 100 $\mu$ F/160V M	CE2CMZNDL101
C657▲	ELECTROLYTIC CAP. 470 $\mu$ F/35V M(VR) or	CE1GMZNTL471
▲	ELECTROLYTIC CAP. 470 $\mu$ F/35V M or	CE1GMZADL471
▲	ELECTROLYTIC CAP. 470 $\mu$ F/35V M	CE1GMZNDL471
C658▲	ELECTROLYTIC CAP. 1000 $\mu$ F/16V M(VR/HC) or	CE1CMZNTL102
▲	ELECTROLYTIC CAP. 1000 $\mu$ F/16V M or	CE1CMZPDL102
▲	ELECTROLYTIC CAP. 1000 $\mu$ F/16V M	CE1CMZADL102
C662▲	ELECTROLYTIC CAP. 1000 $\mu$ F/25V M or	CE1EMZNTL102
▲	ELECTROLYTIC CAP. 1000 $\mu$ F/25V M or	CE1EMZPDL102
▲	ELECTROLYTIC CAP. 1000 $\mu$ F/25V M	CE1EMZADL102
C667	ELECTROLYTIC CAP. 1 $\mu$ F/50V M or	CE1JMASTL1R0
	ELECTROLYTIC CAP. 1 $\mu$ F/50V M or	CE1JMASDL1R0
	ELECTROLYTIC CAP. 1 $\mu$ F/50V M or	CE1JMASDL010
	ELECTROLYTIC CAP. 1 $\mu$ F/50V M	CE1JMASTL010
C681	ELECTROLYTIC CAP. 10 $\mu$ F/50V M or	CE1JMASTL100
	ELECTROLYTIC CAP. 10 $\mu$ F/50V M	CE1JMASDL100
C682	ELECTROLYTIC CAP. 100 $\mu$ F/10V M or	CE1AMASTL101
	ELECTROLYTIC CAP. 100 $\mu$ F/10V M	CE1AMASDL101
C684	ELECTROLYTIC CAP. 100 $\mu$ F/10V M or	CE1AMASTL101
	ELECTROLYTIC CAP. 100 $\mu$ F/10V M	CE1AMASDL101
C685	ELECTROLYTIC CAP. 100 $\mu$ F/10V M or	CE1AMASTL101
	ELECTROLYTIC CAP. 100 $\mu$ F/10V M	CE1AMASDL101
C725	CHIP CERAMIC CAP. B K 1500pF/50V	CHD1JKB0B152

Ref. No.	Description	Part No.
C726	ELECTROLYTIC CAP. 0.47 $\mu$ F/50V M or	CE1JMASTLR47
	ELECTROLYTIC CAP. 0.47 $\mu$ F/50V M	CE1JMASDLR47
C728	CHIP CERAMIC CAP. B K 1500pF/50V	CHD1JKB0B152
C729	ELECTROLYTIC CAP. 0.47 $\mu$ F/50V M or	CE1JMASTLR47
	ELECTROLYTIC CAP. 0.47 $\mu$ F/50V M	CE1JMASDLR47
C773	ELECTROLYTIC CAP. 100 $\mu$ F/10V M or	CE1AMASTL101
	ELECTROLYTIC CAP. 100 $\mu$ F/10V M	CE1AMASDL101
C801	ELECTROLYTIC CAP. 220 $\mu$ F/16V M or	CE1CMASTL221
	ELECTROLYTIC CAP. 220 $\mu$ F/16V M	CE1CMASDL221
C802	ELECTROLYTIC CAP. 220 $\mu$ F/16V M or	CE1CMASTL221
	ELECTROLYTIC CAP. 220 $\mu$ F/16V M	CE1CMASDL221
C803	FILM CAP.(P) 0.1 $\mu$ F/50V J or	CMA1JJS00104
	FILM CAP.(P) 0.1 $\mu$ F/50V J	CA1J104MS029
C804	FILM CAP.(P) 0.1 $\mu$ F/50V J or	CMA1JJS00104
	FILM CAP.(P) 0.1 $\mu$ F/50V J	CA1J104MS029
C807	ELECTROLYTIC CAP. 4.7 $\mu$ F/50V M or	CE1JMASTL4R7
	ELECTROLYTIC CAP. 4.7 $\mu$ F/50V M	CE1JMASDL4R7
C811	ELECTROLYTIC CAP. 1000 $\mu$ F/25V M or	CE1EMZNTL102
	ELECTROLYTIC CAP. 1000 $\mu$ F/25V M or	CE1EMZPDL102
	ELECTROLYTIC CAP. 1000 $\mu$ F/25V M	CE1EMZADL102
C833	ELECTROLYTIC CAP. 100 $\mu$ F/16V M or	CE1CMASTL101
	ELECTROLYTIC CAP. 100 $\mu$ F/16V M	CE1CMASDL101
<b>CONNECTORS</b>		
CN571▲	CONNECTOR BASE, 5P TV-50P-05-V3 or	J3TVC05TG002
▲	CONNECTOR BASE, 5P RTB-1.5-5P or	J3RTC05JG001
▲	CONNECTOR BASE, 5P W-P3005-02	1730812
CN691▲	CONNECTOR BASE, 2P TV-50P-02-V3 or	J3TVC02TG002
▲	CONNECTOR BASE, 2P RTB-1.5-2P	J3RTC02JG001
CN801	STRAIGHT CONNECTOR BASE 00 8283 0212 00 000 or	J383C02UG002
	STRAIGHT PIN HEADER, 2P 173981-2	1770258
CN802	STRAIGHT CONNECTOR BASE 00 8283 0212 00 000 or	J383C02UG002
	STRAIGHT PIN HEADER, 2P 173981-2	1770258
<b>DIODES</b>		
D101	SWITCHING DIODE 1SS133(T-77) or	QDTZ001SS133
	SWITCHING DIODE 1N4148	NDTZ001N4148
D102	SWITCHING DIODE 1SS133(F-77) or	QDTZ001SS133
	SWITCHING DIODE 1N4148	NDTZ001N4148
D131	ZENER DIODE MTZJT-775.1B or	QDTB0MTZJ5R1
	ZENER DIODE DZ-5.1BSBT265	NDTB0DZ5R1BS
D322	SWITCHING DIODE 1SS133(T-77) or	QDTZ001SS133
	SWITCHING DIODE 1N4148	NDTZ001N4148
D323	ZENER DIODE MTZJT-779.1B or	QDTB0MTZJ9R1
	ZENER DIODE DZ-9.1BSBT265	NDTB0DZ9R1BS
D326	SWITCHING DIODE 1SS133(T-77) or	QDTZ001SS133
	SWITCHING DIODE 1N4148	NDTZ001N4148
D351	SWITCHING DIODE 1SS133(T-77) or	QDTZ001SS133
	SWITCHING DIODE 1N4148	NDTZ001N4148
D352	SWITCHING DIODE 1SS133(F-77) or	QDTZ001SS133
	SWITCHING DIODE 1N4148	NDTZ001N4148
D353	SWITCHING DIODE 1SS133(T-77) or	QDTZ001SS133
	SWITCHING DIODE 1N4148	NDTZ001N4148
D501	DIODE FR104-B or	NDLZ000FR104
	RECTIFIER DIODE ERA22-02 or	QDPZ0ERA2202
	RECTIFIER DIODE 10ELS2 or	QDQZ0010ELS2
	DIODE 10ERB20	QDLZ010ERB20
D502▲	ZENER DIODE MTZJT-7720B or	QDTB00MTZJ20
▲	ZENER DIODE DZ-20BSBT265	NDTB00DZ20BS
D503▲	SWITCHING DIODE 1SS133(T-77) or	QDTZ001SS133
▲	SWITCHING DIODE 1N4148	NDTZ001N4148

Ref. No.	Description	Part No.
D511	ZENER DIODE MTZJT-7715B or ZENER DIODE DZ-15BSBT265	QDTB00MTZJ15 NDTB00DZ15BS
D545	ZENER DIODE MTZJT-776.8B or ZENER DIODE DZ-6.8BSBT265	QDTB0MTZJ6R8 NDTB0DZ6R8BS
D546	SWITCHING DIODE 1SS133(T-77) or SWITCHING DIODE 1N4148	QDTZ001SS133 NDTZ001N4148
D547	SWITCHING DIODE 1SS133(T-77) or SWITCHING DIODE 1N4148	QDTZ001SS133 NDTZ001N4148
D552▲	ZENER DIODE MTZJT-7715B or ▲ ZENER DIODE DZ-15BSBT265	QDTB00MTZJ15 NDTB00DZ15BS
D558	SWITCHING DIODE 1SS133(T-77) or SWITCHING DIODE 1N4148	QDTZ001SS133 NDTZ001N4148
D572	FAST RECOVERY DIODE ERA22-04 or RECTIFIER DIODE 10ELS4	QDPZ0ERA2204 QDQZ0010ELS4
D580▲	DIODE ERD07-15	QDLZ0ERD0715
D582▲	FAST RECOVERY DIODE ERD38-06L	AERD3806L000
D583	SWITCHING DIODE 1SS133(T-77) or SWITCHING DIODE 1N4148	QDTZ001SS133 NDTZ001N4148
D584▲	SWITCHING DIODE 1SS133(T-77) or ▲ SWITCHING DIODE 1N4148	QDTZ001SS133 NDTZ001N4148
D585	SWITCHING DIODE 1SS133(T-77) or SWITCHING DIODE 1N4148	QDTZ001SS133 NDTZ001N4148
D591▲	ZENER DIODE MTZJT-7736B or ▲ ZENER DIODE DZ-36BSBT265	QDTB00MTZJ36 NDTB00DZ36BS
D595▲	SWITCHING DIODE 1SS133(T-77) or ▲ SWITCHING DIODE 1N4148	QDTZ001SS133 NDTZ001N4148
D597	ZENER DIODE MTZJT-776.8B or ZENER DIODE DZ-6.8BSBT265	QDTB0MTZJ6R8 NDTB0DZ6R8BS
D605▲	DIODE 1N5406 or ▲ DIODE ERC04-06L3	NDLZ001N5406 QD4Z0ERC0406
D606▲	DIODE 1N5406 or ▲ DIODE ERC04-06L3	NDLZ001N5406 QD4Z0ERC0406
D607▲	DIODE 1N5406 or ▲ DIODE ERC04-06L3	NDLZ001N5406 QD4Z0ERC0406
D608▲	DIODE 1N5406 or ▲ DIODE ERC04-06L3	NDLZ001N5406 QD4Z0ERC0406
D609	SWITCHING DIODE 1SS133(T-77) or SWITCHING DIODE 1N4148	QDTZ001SS133 NDTZ001N4148
D611▲	ZENER DIODE MTZJT-7720B or ▲ ZENER DIODE DZ-20BSBT265	QDTB00MTZJ20 NDTB00DZ20BS
D612▲	ZENER DIODE MTZJT-7718B or ▲ ZENER DIODE DZ-18BSBT265	QDTB00MTZJ18 NDTB00DZ18BS
D613	ZENER DIODE MTZJT-777.5B or ZENER DIODE DZ-7.5BSBT265	QDTB0MTZJ7R5 NDTB0DZ7R5BS
D614	SWITCHING DIODE 1SS133(T-77) or SWITCHING DIODE 1N4148	QDTZ001SS133 NDTZ001N4148
D615▲	SWITCHING DIODE 1N4148 T-77	QDTZ001N4148
D616▲	ZENER DIODE MTZJT-7715B or ▲ ZENER DIODE DZ-15BSBT265	QDTB00MTZJ15 NDTB00DZ15BS
D623	SWITCHING DIODE 1SS133(T-77) or SWITCHING DIODE 1N4148	QDTZ001SS133 NDTZ001N4148
D624	SWITCHING DIODE 1SS133(T-77) or SWITCHING DIODE 1N4148	QDTZ001SS133 NDTZ001N4148
D631	SWITCHING DIODE 1SS133(T-77) or SWITCHING DIODE 1N4148	QDTZ001SS133 NDTZ001N4148
D632	SWITCHING DIODE 1SS133(T-77) or SWITCHING DIODE 1N4148	QDTZ001SS133 NDTZ001N4148
D633	SWITCHING DIODE 1SS133(T-77) or SWITCHING DIODE 1N4148	QDTZ001SS133 NDTZ001N4148
D651▲	FAST RECOVERY DIODE 30DF6 or ▲ FAST RECOVERY DIODE FE201-6 or	QDWZ00030DF6 QDLZ00FE2016

Ref. No.	Description	Part No.
▲	DIODE 30PRA60	QDLZ030PRA60
D652▲	DIODE FR154 or ▲ FAST RECOVERY DIODE ERB44-02	NDLZ000FR154 QDPZ0ERB4402
D653▲	DIODE FR154 or ▲ FAST RECOVERY DIODE ERB44-02	NDLZ000FR154 QDPZ0ERB4402
D654▲	SWITCHING DIODE 1SS133(T-77) or ▲ SWITCHING DIODE 1N4148	QDTZ001SS133 NDTZ001N4148
D656▲	ZENER DIODE MTZJT-776.8B or ▲ ZENER DIODE DZ-6.8BSBT265	QDTB0MTZJ6R8 NDTB0DZ6R8BS
D657▲	DIODE FR154 or ▲ FAST RECOVERY DIODE ERB44-02	NDLZ000FR154 QDPZ0ERB4402
D660	SWITCHING DIODE 1SS133(T-77) or SWITCHING DIODE 1N4148	QDTZ001SS133 NDTZ001N4148
D661▲	SWITCHING DIODE 1SS133(T-77) or ▲ SWITCHING DIODE 1N4148	QDTZ001SS133 NDTZ001N4148
D666	ZENER DIODE MTZJT-7736B or ZENER DIODE DZ-36BSBT265	QDTB00MTZJ36 NDTB00DZ36BS
D671	SWITCHING DIODE 1SS133(T-77) or SWITCHING DIODE 1N4148	QDTZ001SS133 NDTZ001N4148
D672	SWITCHING DIODE 1SS133(T-77) or SWITCHING DIODE 1N4148	QDTZ001SS133 NDTZ001N4148
D675	SWITCHING DIODE 1SS133(T-77) or SWITCHING DIODE 1N4148	QDTZ001SS133 NDTZ001N4148
D676	ZENER DIODE MTZJT-7715B or ZENER DIODE DZ-15BSBT265	QDTB00MTZJ15 NDTB00DZ15BS
D680▲	DIODE 1ZC36 or ▲ ZENER DIODE RD39FB	QDQZ0001ZC36 QDQZ000RD39F
D685▲	SWITCHING DIODE 1SS133(T-77) or ▲ SWITCHING DIODE 1N4148	QDTZ001SS133 NDTZ001N4148
D686▲	SWITCHING DIODE 1SS133(T-77) or ▲ SWITCHING DIODE 1N4148	QDTZ001SS133 NDTZ001N4148
D696▲	SWITCHING DIODE 1SS133(T-77) or ▲ SWITCHING DIODE 1N4148	QDTZ001SS133 NDTZ001N4148
D801	ZENER DIODE MTZJT-773.0B or ZENER DIODE DZ-3.0BSBT265	QDTB0MTZJ3R0 NDTB0DZ3R0BS
D841▲	SWITCHING DIODE 1SS133(T-77) or ▲ SWITCHING DIODE 1N4148	QDTZ001SS133 NDTZ001N4148
D842▲	ZENER DIODE MTZJT-775.1B or ▲ ZENER DIODE DZ-5.1BSBT265	QDTB0MTZJ5R1 NDTB0DZ5R1BS
<b>ICS</b>		
IC31	IC:VIF/SIF M61113FP	QSZBA0SHT019
IC111	IC M61271M8-058FP-71	QSZAA0RMB182
IC151	IC:MEMORY S524C20D21 or IC:MEMORY AT24C02N-10SC or IC(EEPROM) M24C02-MN6 or IC:MEMORY BR24C02F-W or IC:MEMORY BR24C02F or IC:EEPROM CAT24WC02Jl or IC(EEP-ROM) M24C02-WMN6	NSZBA0SSM028 NSMMA0SAZ012 NSMMA0SSS028 QSMBA0SRM003 QSMMA0SRM003 NSZBA0SBG001 NSZAA0SSS004
IC431	IC:MTS DECORDER AN5832SA-E1	QSZBA0TMS003
IC551▲	IC:VERTICAL OUTPUT LA78041-E	QSZBA0SSY006
IC601▲	PHOTOCOUPLER PS2501-1W or ▲ PHOTO COUPLER PS2501-1L or ▲ PHOTOCOUPLER LTV-817B-F or ▲ PHOTOCOUPLER LTV-817C-F	QPEWOPS25011 QPEL0PS25011 NPEB0LTV817F NPEC0LTV817F
IC801	IC AN17812A	QSZBA0SMS017
<b>COILS</b>		
L12	INDUCTOR 22μH-K-5FT or INDUCTOR 22μH-K	LLARKBSTU220 LLARKDQKA220
L32	INDUCTOR 15μH-J-26T or	LLAXJATTU150



Ref. No.	Description	Part No.
	INDUCTOR 15μH-K-26T	LLAXKDTKA150
L34	INDUCTOR 18μH-J-26T or	LLAXJATTU180
	INDUCTOR 18μH-K-26T	LLAXKDTKA180
L51	INDUCTOR 100μH-K-5FT or	LLARKBSTU101
	INDUCTOR 100μH-K	LLARKDQKA101
L112	INDUCTOR 22μH-K-5FT or	LLARKBSTU220
	INDUCTOR 22μH-K	LLARKDQKA220
L301	PCB JUMPER D0.6-P5.0	JW5.0T
L551	LINEARITY COIL ELH5L6136N or	LLBD00PMS008
	LINEARITY COIL ST0108	LLBD00ZY2005
L562	LINEARITY COIL ST02LN or	LLBD00ZY2003
	CHOKE COIL ELC13B102L or	LLC102KMS001
	CHOKE COIL CSA-LF048	LLBD00ZSA003
L588	CHOKE COIL 47μH-K or	LLBD00PKV007
	POT COIL 47μH K	LLBD00DQE001
L601▲	LINE FILTER JLB2808 or	LLBG00ZXB004
▲	LINE FILTER MS036 or	LLBG00ZY2009
▲	LINE FILTER CSA-LF032	LLBG00ZSA007
<b>TRANSISTORS</b>		
Q31	RES. BUILT-IN TRANSISTOR BA1F4M-T or	QQSZ00BA1F4M
	RES. BUILT-IN TRANSISTOR KRC103M	NQSZ0KRC103M
Q111▲	TRANSISTOR 2SC2785(F) or	QQSF02SC2785
▲	TRANSISTOR 2SC2785(H) or	QQSH02SC2785
▲	TRANSISTOR 2SC2785(J) or	QQSJ02SC2785
▲	TRANSISTOR KTC3199(GR) or	NQS10KTC3199
▲	TRANSISTOR KTC3198(GR) or	NQS40KTC3198
▲	TRANSISTOR 2SC3331(T)-AANP or	2SC3331TZ
▲	TRANSISTOR 2SC3331(U)-AANP or	2SC3331UZ
▲	TRANSISTOR 2SC1815-GR(TPE2)	QQS102SC1815
Q161	RES. BUILT-IN TRANSISTOR BA1F4M-T or	QQSZ00BA1F4M
	RES. BUILT-IN TRANSISTOR KRC103M	NQSZ0KRC103M
Q321	TRANSISTOR 2SC2785(F) or	QQSF02SC2785
	TRANSISTOR 2SC2785(H) or	QQSH02SC2785
	TRANSISTOR 2SC2785(J) or	QQSJ02SC2785
	TRANSISTOR KTC3199(GR) or	NQS10KTC3199
	TRANSISTOR KTC3198(GR) or	NQS40KTC3198
	TRANSISTOR 2SC3331(T)-AANP or	2SC3331TZ
	TRANSISTOR 2SC3331(U)-AANP or	2SC3331UZ
	TRANSISTOR 2SC1815-GR(TPE2)	QQS102SC1815
Q361	TRANSISTOR 2SC2785(F) or	QQSF02SC2785
	TRANSISTOR 2SC2785(H) or	QQSH02SC2785
	TRANSISTOR 2SC2785(J) or	QQSJ02SC2785
	TRANSISTOR KTC3199(GR) or	NQS10KTC3199
	TRANSISTOR KTC3198(GR) or	NQS40KTC3198
	TRANSISTOR 2SC3331(T)-AANP or	2SC3331TZ
	TRANSISTOR 2SC3331(U)-AANP or	2SC3331UZ
	TRANSISTOR 2SC1815-GR(TPE2)	QQS102SC1815
Q511	RES. BUILT-IN TRANSISTOR BA1F4M-T or	QQSZ00BA1F4M
	RES. BUILT-IN TRANSISTOR KRC103M	NQSZ0KRC103M
Q512	RES. BUILT-IN TRANSISTOR BA1F4M-T or	QQSZ00BA1F4M
	RES. BUILT-IN TRANSISTOR KRC103M	NQSZ0KRC103M
Q547	TRANSISTOR 2SC2785(F) or	QQSF02SC2785
	TRANSISTOR 2SC2785(H) or	QQSH02SC2785
	TRANSISTOR 2SC2785(J) or	QQSJ02SC2785
	TRANSISTOR KTC3199(GR) or	NQS10KTC3199
	TRANSISTOR KTC3198(GR) or	NQS40KTC3198
	TRANSISTOR 2SC3331(T)-AANP or	2SC3331TZ
	TRANSISTOR 2SC3331(U)-AANP or	2SC3331UZ
	TRANSISTOR 2SC1815-GR(TPE2)	QQS102SC1815
Q551	TRANSISTOR 2SA1175(F) or	QQSF02SA1175

Ref. No.	Description	Part No.
	TRANSISTOR KTA1267(GR) or	NQS10KTA1267
	TRANSISTOR KTA1266(GR) or	NQS40KTA1266
	TRANSISTOR 2SA1318(T)-AANP or	2SA1318TZ
	TRANSISTOR 2SA1318(U)-AANP or	2SA1318UZ
	TRANSISTOR 2SA1015-GR(TPE2)	QQS102SA1015
Q552▲	TRANSISTOR 2SD1666R or	QKER02SD1666
▲	TRANSISTOR 2SD1666S or	QCES02SD1666
▲	TRANSISTOR KTD2059(O) or	NQ400KTD2059
▲	TRANSISTOR KTD2059(Y) or	NQ4Y0KTD2059
▲	TRANSISTOR 2SD1825	Q2SD1825****
Q561	TRANSISTOR 2SC2785(F) or	QQSF02SC2785
	TRANSISTOR 2SC2785(H) or	QQSH02SC2785
	TRANSISTOR 2SC2785(J) or	QQSJ02SC2785
	TRANSISTOR KTC3199(GR) or	NQS10KTC3199
	TRANSISTOR KTC3198(GR) or	NQS40KTC3198
	TRANSISTOR 2SC3331(T)-AANP or	2SC3331TZ
	TRANSISTOR 2SC3331(U)-AANP or	2SC3331UZ
	TRANSISTOR 2SC1815-GR(TPE2)	QQS102SC1815
Q571▲	TRANSISTOR 2SC5978 or	QQZZ02SC5978
▲	TRANSISTOR TT2190LS or	QQZZTT2190LS
▲	TRANSISTOR TT2142	QQZZ00TT2142
Q572	TRANSISTOR 2SC1627Y-TPE2	QQSY02SC1627
Q601▲	MOS FET 2SK3561	QFWZ02SK3561
Q602▲	TRANSISTOR 2SC2120-O-TPE2 or	QQS002SC2120
▲	TRANSISTOR 2SC2120-Y(TPE2)	QQSY02SC2120
Q631	TRANSISTOR 2SA1175(F) or	QQSF02SA1175
	TRANSISTOR KTA1267(GR) or	NQS10KTA1267
	TRANSISTOR KTA1266(GR) or	NQS40KTA1266
	TRANSISTOR 2SA1318(T)-AANP or	2SA1318TZ
	TRANSISTOR 2SA1318(U)-AANP or	2SA1318UZ
	TRANSISTOR 2SA1015-GR(TPE2)	QQS102SA1015
Q652▲	TRANSISTOR 2SC2785(F) or	QQSF02SC2785
▲	TRANSISTOR 2SC2785(H) or	QQSH02SC2785
▲	TRANSISTOR 2SC2785(J) or	QQSJ02SC2785
▲	TRANSISTOR KTC3199(GR) or	NQS10KTC3199
▲	TRANSISTOR KTC3198(GR) or	NQS40KTC3198
▲	TRANSISTOR 2SC3331(T)-AANP or	2SC3331TZ
▲	TRANSISTOR 2SC3331(U)-AANP or	2SC3331UZ
▲	TRANSISTOR 2SC1815-GR(TPE2)	QQS102SC1815
Q672▲	TRANSISTOR 2SA1175(F) or	QQSF02SA1175
▲	TRANSISTOR KTA1267(GR) or	NQS10KTA1267
▲	TRANSISTOR KTA1266(GR) or	NQS40KTA1266
▲	TRANSISTOR 2SA1318(T)-AANP or	2SA1318TZ
▲	TRANSISTOR 2SA1318(U)-AANP or	2SA1318UZ
▲	TRANSISTOR 2SA1015-GR(TPE2)	QQS102SA1015
Q673	TRANSISTOR 2SC2785(F) or	QQSF02SC2785
	TRANSISTOR 2SC2785(H) or	QQSH02SC2785
	TRANSISTOR 2SC2785(J) or	QQSJ02SC2785
	TRANSISTOR KTC3199(GR) or	NQS10KTC3199
	TRANSISTOR KTC3198(GR) or	NQS40KTC3198
	TRANSISTOR 2SC3331(T)-AANP or	2SC3331TZ
	TRANSISTOR 2SC3331(U)-AANP or	2SC3331UZ
	TRANSISTOR 2SC1815-GR(TPE2)	QQS102SC1815
Q674	TRANSISTOR 2SC2785(F) or	QQSF02SC2785
	TRANSISTOR 2SC2785(H) or	QQSH02SC2785
	TRANSISTOR 2SC2785(J) or	QQSJ02SC2785
	TRANSISTOR KTC3199(GR) or	NQS10KTC3199
	TRANSISTOR KTC3198(GR) or	NQS40KTC3198
	TRANSISTOR 2SC3331(T)-AANP or	2SC3331TZ
	TRANSISTOR 2SC3331(U)-AANP or	2SC3331UZ
	TRANSISTOR 2SC1815-GR(TPE2)	QQS102SC1815

Ref. No.	Description	Part No.
Q681	TRANSISTOR 2SC2120-O-TPE2 or	QQS002SC2120
	TRANSISTOR 2SC2120-Y(TPE2)	QQSY02SC2120
Q682	TRANSISTOR 2SD400(E) or	QQUE002SD400
	TRANSISTOR 2SD400(F) or	QQUF002SD400
	TRANSISTOR KTC3205(Y) or	NQSY0KTC3205
	TRANSISTOR KTC3205OAT	NQS00KTC3205
Q696	RES. BUILT-IN TRANSISTOR BA1F4M-T or	QQSZ00BA1F4M
	RES. BUILT-IN TRANSISTOR KRC103M	NQSZ0KRC103M
Q801	TRANSISTOR 2SC2785(F) or	QQSF02SC2785
	TRANSISTOR 2SC2785(H) or	QQSH02SC2785
	TRANSISTOR 2SC2785(J) or	QQSJ02SC2785
	TRANSISTOR KTC3199(GR) or	NQS10KTC3199
	TRANSISTOR KTC3198(GR) or	NQS40KTC3198
	TRANSISTOR 2SC3331(T)-AANP or	2SC3331TZ
	TRANSISTOR 2SC3331(U)-AANP or	2SC3331UZ
	TRANSISTOR 2SC1815-GR(TPE2)	QQS102SC1815
Q811	TRANSISTOR 2SC2785(F) or	QQSF02SC2785
	TRANSISTOR 2SC2785(H) or	QQSH02SC2785
	TRANSISTOR 2SC2785(J) or	QQSJ02SC2785
	TRANSISTOR KTC3199(GR) or	NQS10KTC3199
	TRANSISTOR KTC3198(GR) or	NQS40KTC3198
	TRANSISTOR 2SC3331(T)-AANP or	2SC3331TZ
	TRANSISTOR 2SC3331(U)-AANP or	2SC3331UZ
	TRANSISTOR 2SC1815-GR(TPE2)	QQS102SC1815
<b>RESISTORS</b>		
R12	PCB JUMPER D0.6-P5.0	JW5.0T
R31	CHIP RES.(1608) 1/10W J 2.2k Ω	RRXAJB5Z0222
R32	CARBON RES. 1/4W J 390 Ω	RCX4JATZ0391
R33	CHIP RES.(1608) 1/10W J 270 Ω	RRXAJB5Z0271
R34	CHIP RES.(1608) 1/10W J 220 Ω	RRXAJB5Z0221
R37	CHIP RES.(1608) 1/10W J 220 Ω	RRXAJB5Z0221
R38	CHIP RES.(1608) 1/10W J 12k Ω	RRXAJB5Z0123
R39	CHIP RES.(1608) 1/10W J 27k Ω	RRXAJB5Z0273
R44	CHIP RES.(1608) 1/10W J 100 Ω	RRXAJB5Z0101
R51	CHIP RES.(1608) 1/10W J 220k Ω	RRXAJB5Z0224
R52	CARBON RES. 1/4W J 220k Ω	RCX4JATZ0224
R54	CARBON RES. 1/4W J 22k Ω	RCX4JATZ0223
R101	CARBON RES. 1/4W J 100 Ω	RCX4JATZ0101
R102	CHIP RES.(1608) 1/10W J 1.5k Ω	RRXAJB5Z0152
R103	CHIP RES.(1608) 1/10W J 2.2k Ω	RRXAJB5Z0222
R104	CHIP RES.(1608) 1/10W J 2.7k Ω	RRXAJB5Z0272
R105	CHIP RES.(1608) 1/10W J 4.7k Ω	RRXAJB5Z0472
R106	CHIP RES.(1608) 1/10W J 8.2k Ω	RRXAJB5Z0822
R108	CHIP RES.(1608) 1/10W J 10k Ω	RRXAJB5Z0103
R109	CHIP RES.(1608) 1/10W J 10k Ω	RRXAJB5Z0103
R111	CARBON RES. 1/4W J 100 Ω	RCX4JATZ0101
R112	CHIP RES.(1608) 1/10W J 10k Ω	RRXAJB5Z0103
R113	CHIP RES.(1608) 1/10W J 270k Ω	RRXAJB5Z0274
R114	CHIP RES.(1608) 1/10W J 1k Ω	RRXAJB5Z0102
R116	CHIP RES. 1/10W J 0 Ω	RRXAJB5Z0000
R121	CHIP RES.(1608) 1/10W J 100 Ω	RRXAJB5Z0101
R122	CHIP RES.(1608) 1/10W J 100 Ω	RRXAJB5Z0101
R123	CHIP RES.(1608) 1/10W J 1k Ω	RRXAJB5Z0102
R131	CHIP RES.(1608) 1/10W J 470 Ω	RRXAJB5Z0471
R133	CHIP RES. 1/10W J 0 Ω	RRXAJB5Z0000
R134	CHIP RES.(1608) 1/10W J 22k Ω	RRXAJB5Z0223
R135	CHIP RES.(1608) 1/10W J 2.2k Ω	RRXAJB5Z0222
R136	CHIP RES.(1608) 1/10W J 100k Ω	RRXAJB5Z0104
R137	CHIP RES.(1608) 1/10W J 100 Ω	RRXAJB5Z0101
R138	CHIP RES.(1608) 1/10W J 220k Ω	RRXAJB5Z0224

Ref. No.	Description	Part No.
R139	CARBON RES. 1/4W J 22k Ω	RCX4JATZ0223
R140	CHIP RES.(1608) 1/10W J 1k Ω	RRXAJB5Z0102
R141	CHIP RES. 1/10W J 0 Ω	RRXAJB5Z0000
R150	CHIP RES. 1/10W J 0 Ω	RRXAJB5Z0000
R153	CHIP RES.(1608) 1/10W J 100 Ω	RRXAJB5Z0101
R154	CHIP RES.(1608) 1/10W J 100 Ω	RRXAJB5Z0101
R161	CHIP RES.(1608) 1/10W J 470 Ω	RRXAJB5Z0471
R162	CHIP RES.(1608) 1/10W J 10k Ω	RRXAJB5Z0103
R163	CHIP RES.(1608) 1/10W J 470 Ω	RRXAJB5Z0471
R164	CHIP RES.(1608) 1/10W J 10k Ω	RRXAJB5Z0103
R165	CHIP RES.(1608) 1/10W J 4.7k Ω	RRXAJB5Z0472
R167	CHIP RES.(1608) 1/10W J 2.7k Ω	RRXAJB5Z0272
R168	CHIP RES.(1608) 1/10W J 4.7k Ω	RRXAJB5Z0472
R170	CHIP RES.(1608) 1/10W J 10k Ω	RRXAJB5Z0103
R171	CHIP RES.(1608) 1/10W J 560 Ω	RRXAJB5Z0561
R172	CHIP RES. 1/10W J 0 Ω	RRXAJB5Z0000
R173	CHIP RES.(1608) 1/10W J 22k Ω	RRXAJB5Z0223
R174	CHIP RES.(1608) 1/10W J 10k Ω	RRXAJB5Z0103
R176	CHIP RES.(1608) 1/10W J 100 Ω	RRXAJB5Z0101
R177	CHIP RES.(1608) 1/10W J 100 Ω	RRXAJB5Z0101
R301	CHIP RES.(1608) 1/10W J 22k Ω	RRXAJB5Z0223
R302	CHIP RES.(1608) 1/10W J 100 Ω	RRXAJB5Z0101
R303	CHIP RES.(1608) 1/10W J 470 Ω	RRXAJB5Z0471
R320	CHIP RES.(1608) 1/10W J 10k Ω	RRXAJB5Z0103
R323	CARBON RES. 1/4W J 2.2k Ω	RCX4JATZ0222
R326	CHIP RES.(1608) 1/10W J 100 Ω	RRXAJB5Z0101
R327	CHIP RES. 1/10W J 0 Ω	RRXAJB5Z0000
R328	CHIP RES.(1608) 1/10W J 3.3k Ω	RRXAJB5Z0332
R329	CHIP RES.(1608) 1/10W J 47k Ω	RRXAJB5Z0473
R330	CHIP RES.(1608) 1/10W J 1k Ω	RRXAJB5Z0102
R342	CHIP RES. 1/10W J 0 Ω	RRXAJB5Z0000
R344	CHIP RES.(1608) 1/10W J 6.8k Ω	RRXAJB5Z0682
R345	CHIP RES.(1608) 1/10W J 10k Ω	RRXAJB5Z0103
R346	CHIP RES.(1608) 1/10W J 1k Ω	RRXAJB5Z0102
R348	CARBON RES. 1/4W J 27k Ω	RCX4JATZ0273
R349	CHIP RES.(1608) 1/10W J 3.3k Ω	RRXAJB5Z0332
R355	CHIP RES.(1608) 1/10W J 33k Ω	RRXAJB5Z0333
R356	CHIP RES.(1608) 1/10W J 100 Ω	RRXAJB5Z0101
R357	CHIP RES.(1608) 1/10W J 100 Ω	RRXAJB5Z0101
R358	CHIP RES.(1608) 1/10W J 100 Ω	RRXAJB5Z0101
R361	CHIP RES.(1608) 1/10W J 10k Ω	RRXAJB5Z0103
R362	CARBON RES. 1/4W J 100 Ω	RCX4JATZ0101
R363	CHIP RES.(1608) 1/10W J 47k Ω	RRXAJB5Z0473
R417	CHIP RES.(1608) 1/10W J 180k Ω	RRXAJB5Z0184
R422	CHIP RES.(1608) 1/10W J 8.2k Ω	RRXAJB5Z0822
R423	CHIP RES.(1608) 1/10W J 3.9k Ω	RRXAJB5Z0392
R427	CHIP RES.(1608) 1/10W J 8.2k Ω	RRXAJB5Z0822
R428	CHIP RES.(1608) 1/10W J 3.9k Ω	RRXAJB5Z0392
R445	CHIP RES.(1608) 1/10W J 3.3k Ω	RRXAJB5Z0332
R503	CARBON RES. 1/4W J 68k Ω	RCX4JATZ0683
R504	CARBON RES. 1/4W J 3.3 Ω	RCX4JATZ03R3
R505	CARBON RES. 1/4W J 1k Ω	RCX4JATZ0102
R506	CARBON RES. 1/4W J 2.7 Ω	RCX4JATZ02R7
R507	CARBON RES. 1/4W J 2.7 Ω	RCX4JATZ02R7
R508	CARBON RES. 1/4W J 2.7 Ω	RCX4JATZ02R7
R511	CARBON RES. 1/4W J 33k Ω	RCX4JATZ0333
R513▲	METAL OXIDE FILM RES. 2W J 5.6 Ω or	RN025R6ZU001
▲	METAL OXIDE FILM RES. 2W J 5.6 Ω	RN025R6DP004
R514	CARBON RES. 1/4W J 2.7k Ω	RCX4JATZ0272
R515	CHIP RES.(1608) 1/10W J 33k Ω	RRXAJB5Z0333
R520▲	CHIP RES.(1608) 1/10W J 22k Ω	RRXAJB5Z0223

Ref. No.	Description	Part No.
R522	CARBON RES. 1/4W J 22k Ω	RCX4JATZ0223
R535	CARBON RES. 1/4W J 470 Ω	RCX4JATZ0471
R541	CARBON RES. 1/4W J 680 Ω	RCX4JATZ0681
R542	CARBON RES. 1/4W J 680 Ω	RCX4JATZ0681
R543	CARBON RES. 1/4W J 680 Ω	RCX4JATZ0681
R544	CARBON RES. 1/4W J 1k Ω	RCX4JATZ0102
R545	CHIP RES.(1608) 1/10W J 6.8k Ω	RRXAJB5Z0682
R546	CHIP RES.(1608) 1/10W J 2.2k Ω	RRXAJB5Z0222
R547	CHIP RES.(1608) 1/10W J 2.7k Ω	RRXAJB5Z0272
R548	CHIP RES.(1608) 1/10W J 47k Ω	RRXAJB5Z0473
R549	CARBON RES. 1/4W J 1.5k Ω	RCX4JATZ0152
R551	METAL OXIDE FILM RES. 2W J 680 Ω or METAL OXIDE FILM RES. 2W J 680 Ω	RN02681ZU001 RN02681DP004
R552▲	METAL OXIDE FILM RES. 1W J 8.2 Ω or ▲ METAL OXIDE FILM RES. 1W J 8.2 Ω	RN018R2ZU001 RN018R2DP003
R553	CARBON RES. 1/4W J 2.2k Ω	RCX4JATZ0222
R554	CARBON RES. 1/4W J 3.9k Ω	RCX4JATZ0392
R555	CARBON RES. 1/4W J 2.2k Ω	RCX4JATZ0222
R556	CARBON RES. 1/4W J 47k Ω	RCX4JATZ0473
R557	CARBON RES. 1/4W J 18k Ω	RCX4JATZ0183
R558	CHIP RES.(1608) 1/10W J 220 Ω	RRXAJB5Z0221
R559	CARBON RES. 1/4W J 22k Ω	RCX4JATZ0223
R560	CHIP RES.(1608) 1/10W J 22k Ω	RRXAJB5Z0223
R561	CARBON RES. 1/4W J 1.2k Ω	RCX4JATZ0122
R562	CARBON RES. 1/4W J 100k Ω	RCX4JATZ0104
R563	CARBON RES. 1/4W J 10k Ω	RCX4JATZ0103
R564	CHIP RES.(1608) 1/10W J 180k Ω	RRXAJB5Z0184
R566	CARBON RES. 1/4W J 8.2k Ω	RCX4JATZ0822
R568	CHIP RES.(1608) 1/10W J 1k Ω	RRXAJB5Z0102
R575▲	CARBON RES. 1/4W J 15 Ω	RCX4JATZ0150
R576	CHIP RES.(1608) 1/10W J 1k Ω	RRXAJB5Z0102
R577	CARBON RES. 1/4W J 330 Ω	RCX4JATZ0331
R578▲	CARBON RES. 1/4W J 15 Ω	RCX4JATZ0150
R579▲	CARBON RES. 1/4W J 15 Ω	RCX4JATZ0150
R581	PCB JUMPER D0.6-P5.0	JW5.0T
R583▲	METAL OXIDE FILM RES. 2W J 6.8 Ω or ▲ METAL OXIDE FILM RES. 2W J 6.8 Ω	RN026R8ZU001 RN026R8DP004
R584▲	CARBON RES. 1/4W J 1k Ω	RCX4JATZ0102
R588▲	CARBON RES. 1/4W J 56k Ω	RCX4JATZ0563
R589	CARBON RES. 1/4W J 56k Ω	RCX4JATZ0563
R590	CARBON RES. 1/4W J 220k Ω	RCX4JATZ0224
R591▲	CARBON RES. 1/4W J 180k Ω	RCX4JATZ0184
R592▲	CARBON RES. 1/4W J 180k Ω	RCX4JATZ0184
R593▲	CARBON RES. 1/4W J 82k Ω	RCX4JATZ0823
R594▲	CARBON RES. 1/4W J 56k Ω	RCX4JATZ0563
R596	CARBON RES. 1/4W J 12k Ω	RCX4JATZ0123
R597	CARBON RES. 1/4W J 8.2k Ω	RCX4JATZ0822
R598▲	CARBON RES. 1/4W J 33k Ω	RCX4JATZ0333
R599▲	CARBON RES. 1/4W J 15k Ω	RCX4JATZ0153
R601▲	CEMENT RES. 5W K 0.56 Ω or ▲ CEMENT RES. 5W K 0.56 Ω or ▲ CEMENT RESISTOR 5W J 0.56 Ω	RW05R56DP007 RW05R56PG001 RW05R56PAK10
R602▲	CARBON RES. 1/4W J 820k Ω	RCX4JATZ0824
R603	CARBON RES. 1/4W J 820k Ω	RCX4JATZ0824
R604	CARBON RES. 1/4W J 820k Ω	RCX4JATZ0824
R605	CARBON RES. 1/4W J 820k Ω	RCX4JATZ0824
R607	CARBON RES. 1/4W J 220 Ω	RCX4JATZ0221
R608	CARBON RES. 1/4W J 220 Ω	RCX4JATZ0221
R609	CARBON RES. 1/4W J 820k Ω	RCX4JATZ0824
R613▲	METAL OXIDE FILM RES. 2W J 0.27 Ω or ▲ METAL RES 2W J 0.27 Ω	RN02JZLZ0R27 RN02JZPZ0R27

Ref. No.	Description	Part No.
R614	CARBON RES. 1/4W J 47 Ω	RCX4JATZ0470
R616	CARBON RES. 1/4W J 10k Ω	RCX4JATZ0103
R618	CARBON RES. 1/4W J 390 Ω	RCX4JATZ0391
R621	CARBON RES. 1/4W J 1.5k Ω	RCX4JATZ0152
R622	CARBON RES. 1/4W J 47 Ω	RCX4JATZ0470
R623	CARBON RES. 1/4W J 39 Ω	RCX4JATZ0390
R630	CHIP RES.(1608) 1/10W J 120k Ω	RRXAJB5Z0124
R631	CARBON RES. 1/4W J 22k Ω	RCX4JATZ0223
R632	CHIP RES.(1608) 1/10W J 10k Ω	RRXAJB5Z0103
R641	PCB JUMPER D0.6-P5.0	JW5.0T
R650▲	PCB JUMPER D0.6-P5.0	JW5.0T
R651▲	METAL RESISTOR 2W J 18k Ω or ▲ METAL OXIDE FILM RES. 2W J 18k Ω	RN02183ZU001 RN02183DP004
R652	CARBON RES. 1/4W J 10k Ω	RCX4JATZ0103
R653	CARBON RES. 1/4W J 18k Ω	RCX4JATZ0183
R654▲	CARBON RES. 1/4W J 1.8k Ω	RCX4JATZ0182
R655	CARBON RES. 1/4W J 1k Ω	RCX4JATZ0102
R656	CHIP RES.(1608) 1/10W J 15k Ω	RRXAJB5Z0153
R657	CHIP RES.(1608) 1/10W J 15k Ω	RRXAJB5Z0153
R658	CARBON RES. 1/4W J 470k Ω	RCX4JATZ0474
R659	CHIP RES.(1608) 1/10W J 10k Ω	RRXAJB5Z0103
R660	CARBON RES. 1/4W J 1k Ω	RCX4JATZ0102
R661▲	CARBON RES. 1/4W J 68k Ω	RCX4JATZ0683
R662▲	CARBON RES. 1/4W J 82k Ω	RCX4JATZ0823
R663▲	PCB JUMPER D0.6-P5.0	JW5.0T
R664▲	CARBON RES. 1/4W J 12k Ω	RCX4JATZ0123
R665▲	CARBON RES. 1/4W J 5.6k Ω	RCX4JATZ0562
R666	CARBON RES. 1/4W J 3.3k Ω	RCX4JATZ0332
R667▲	CARBON RES. 1/4W J 27k Ω	RCX4JATZ0273
R668▲	CARBON RES. 1/4W J 33k Ω	RCX4JATZ0333
R669▲	CARBON RES. 1/4W J 27k Ω	RCX4JATZ0273
R670▲	CARBON RES. 1/4W J 100k Ω	RCX4JATZ0104
R671	CARBON RES. 1/4W J 3.3k Ω	RCX4JATZ0332
R672	CARBON RES. 1/4W J 3.3k Ω	RCX4JATZ0332
R673	CARBON RES. 1/4W J 100k Ω	RCX4JATZ0104
R674	CHIP RES.(1608) 1/10W J 22k Ω	RRXAJB5Z0223
R675	CARBON RES. 1/4W J 15k Ω	RCX4JATZ0153
R676	CHIP RES.(1608) 1/10W J 10k Ω	RRXAJB5Z0103
R677	CARBON RES. 1/4W J 68k Ω	RCX4JATZ0683
R678	CHIP RES.(1608) 1/10W J 47k Ω	RRXAJB5Z0473
R680	CHIP RES.(1608) 1/10W J 10k Ω	RRXAJB5Z0103
R681▲	CARBON RES. 1/4W J 12 Ω	RCX4JATZ0120
R682▲	METAL OXIDE FILM RES. 2W J 47 Ω or ▲ METAL OXIDE FILM RES. 2W J 47 Ω	RN02470ZU001 RN02470DP004
R683▲	METAL OXIDE FILM RES. 2W J 47 Ω or ▲ METAL OXIDE FILM RES. 2W J 47 Ω	RN02470ZU001 RN02470DP004
R684▲	PCB JUMPER D0.6-P5.0	JW5.0T
R685▲	PCB JUMPER D0.6-P5.0	JW5.0T
R686	CARBON RES. 1/4W J 47 Ω	RCX4JATZ0470
R687	CARBON RES. 1/4W J 10 Ω	RCX4JATZ0100
R694	CARBON RES. 1/4W J 4.7k Ω	RCX4JATZ0472
R696	CARBON RES. 1/4W J 10 Ω	RCX4JATZ0100
R721	CHIP RES.(1608) 1/10W J 75 Ω	RRXAJB5Z0750
R724	CHIP RES.(1608) 1/10W J 47k Ω	RRXAJB5Z0473
R725	CHIP RES.(1608) 1/10W J 33k Ω	RRXAJB5Z0333
R726	CHIP RES.(1608) 1/10W J 18k Ω	RRXAJB5Z0183
R727	CHIP RES.(1608) 1/10W J 47k Ω	RRXAJB5Z0473
R728	CHIP RES.(1608) 1/10W J 33k Ω	RRXAJB5Z0333
R729	CHIP RES.(1608) 1/10W J 18k Ω	RRXAJB5Z0183
R801	CARBON RES. 1/2W J 100 Ω or CARBON RES. 1/2W J 100 Ω or	RCX2JZQZ0101 RCX2101KA013

Ref. No.	Description	Part No.
	CARBON RES. 1/2W J 100 Ω	RCX2JZPZ0101
R802	CARBON RES. 1/2W J 100 Ω or	RCX2JZQZ0101
	CARBON RES. 1/2W J 100 Ω or	RCX2101KA013
	CARBON RES. 1/2W J 100 Ω	RCX2JZPZ0101
R803	CARBON RES. 1/4W J 100 Ω	RCX4JATZ0101
R804	CARBON RES. 1/4W J 100 Ω	RCX4JATZ0101
R811	CHIP RES.(1608) 1/10W J 10k Ω	RRXAJB5Z0103
R812	CHIP RES.(1608) 1/10W J 82k Ω	RRXAJB5Z0823
R813	CHIP RES.(1608) 1/10W J 1k Ω	RRXAJB5Z0102
R814	CHIP RES.(1608) 1/10W J 10k Ω	RRXAJB5Z0103
R841	METAL OXIDE FILM RES. 1W J 1.2 Ω or	RN011R2ZU001
	METAL OXIDE FILM RES. 1W J 1.2 Ω	RN011R2DP003
R842▲	PCB JUMPER D0.6-P5.0	JW5.0T
R843▲	CHIP RES.(1608) 1/10W J 2.2k Ω	RRXAJB5Z0222
R862	CHIP RES. 1/10W J 0 Ω	RRXAJB5Z0000
R863	CHIP RES.(1608) 1/10W J 10k Ω	RRXAJB5Z0103
<b>SWITCHES</b>		
SW101	TACT SWITCH SKQSAB or	SST0101AL038
	TACT SWITCH KSM0612B or	SST0101HH003
	TACT SWITCH SKHHAM or	SST0101AL029
	TACT SWITCH TC-1104(H=5.0)	SST0101DNG02
SW102	TACT SWITCH SKQSAB or	SST0101AL038
	TACT SWITCH KSM0612B or	SST0101HH003
	TACT SWITCH SKHHAM or	SST0101AL029
	TACT SWITCH TC-1104(H=5.0)	SST0101DNG02
SW103	TACT SWITCH SKQSAB or	SST0101AL038
	TACT SWITCH KSM0612B or	SST0101HH003
	TACT SWITCH SKHHAM or	SST0101AL029
	TACT SWITCH TC-1104(H=5.0)	SST0101DNG02
SW104	TACT SWITCH SKQSAB or	SST0101AL038
	TACT SWITCH KSM0612B or	SST0101HH003
	TACT SWITCH SKHHAM or	SST0101AL029
	TACT SWITCH TC-1104(H=5.0)	SST0101DNG02
SW105	TACT SWITCH SKQSAB or	SST0101AL038
	TACT SWITCH KSM0612B or	SST0101HH003
	TACT SWITCH SKHHAM or	SST0101AL029
	TACT SWITCH TC-1104(H=5.0)	SST0101DNG02
SW106	TACT SWITCH SKQSAB or	SST0101AL038
	TACT SWITCH KSM0612B or	SST0101HH003
	TACT SWITCH SKHHAM or	SST0101AL029
	TACT SWITCH TC-1104(H=5.0)	SST0101DNG02
<b>MISCELLANEOUS</b>		
AC601▲	AC CORD LA-2413	WAC0172LW007
B2	HEAT SINK(PIJ)ASSEMBLY L2700UA	0EM408529
B3	HEAT SINK(PIH)ASSEMBLY L2700UA	0EM408525
B4	HEAT SINK(PII)ASSEMBLY L2700UA	0EM408527
BC11	BEAD INDUCTORS FBR07HA121TB-00	LLBF00ZTU021
BC571	BEAD INDUCTORS FBA04HA600VB-00	LLBF00STU026
BC602	PCB JUMPER D0.6-P5.0	JW5.0T
BC603	BEAD INDUCTORS FBR07HA121TB-00	LLBF00ZTU021
BC652	BEAD INDUCTORS FBR07HA121TB-00	LLBF00ZTU021
BC653	BEAD INDUCTORS FBR07HA121TB-00	LLBF00ZTU021
BC654	BEAD INDUCTORS FBR07HA121TB-00	LLBF00ZTU021
BC655	BEAD INDUCTORS FBR07HA121TB-00	LLBF00ZTU021
BC657	BEAD INDUCTORS FBR07HA121TB-00	LLBF00ZTU021
BC691	BEAD INDUCTORS FBR07HA121TB-00	LLBF00ZTU021
CF31	CERAMIC TRAP 4.5MHz or	FBE455PMR003
	CERAMIC TRAP 4.5MHz	FBE455PMS002
CF32	CERAMIC FILTER SFSRA4M50CF00-B0 or	FBB455PMR004
	CERAMIC FILTER 4.5MHz	FBB455PMS001

Ref. No.	Description	Part No.
CLN301	WIRE ASSEMBLY WX1L1200-102	WX1L1200-102
CLN501	WIRE ASSEMBLY WX1L1200-103	WX1L1200-103
F601▲	FUSE 4A/125V 237 TYPE or	PAGJ20CAG402
▲	FUSE STC4A125V U/CT or	PAGE20CW3402
▲	FUSE 4.00A/125V	PAGG20CNG402
FH601	FUSE HOLDER MSF-015 or	XH01Z00LY001
	FUSE HOLDER FH-V-03078 or	XH01Z00DK001
	HOLDER, FUSE CNT41-0014	1790424
FH602	FUSE HOLDER MSF-015 or	XH01Z00LY001
	FUSE HOLDER FH-V-03078 or	XH01Z00DK001
	HOLDER, FUSE CNT41-0014	1790424
GP641▲	GAP. FNR-G3.10D	FAZ000LD6005
J118	CHIP RES. 1/10W J 0 Ω	RRXAJB5Z0000
J120	CHIP RES. 1/10W J 0 Ω	RRXAJB5Z0000
J135	CHIP RES. 1/10W J 0 Ω	RRXAJB5Z0000
J180	CHIP RES. 1/10W J 0 Ω	RRXAJB5Z0000
J196	CHIP RES. 1/10W J 0 Ω	RRXAJB5Z0000
J242	CHIP RES. 1/10W J 0 Ω	RRXAJB5Z0000
JC704	CHIP RES. 1/10W J 0 Ω	RRXAJB5Z0000
JC812	CHIP RES. 1/10W J 0 Ω	RRXAJB5Z0000
JC814	CHIP RES. 1/10W J 0 Ω	RRXAJB5Z0000
JC815	CHIP RES. 1/10W J 0 Ω	RRXAJB5Z0000
JC816	CHIP RES. 1/10W J 0 Ω	RRXAJB5Z0000
JC817	CHIP RES. 1/10W J 0 Ω	RRXAJB5Z0000
JK701	RCA JACK 1P(YELLOW)WITH SWITCH AV1-09S-3 or	JYRL010RP009
	RCA JACK(YELLOW) MTJ-032-06A-20	JYRL010LY013
JK702	RCA JACK 1P(WHITE)WITH SWITCH AV1-09S-4 or	JYRL010RP010
	RCA JACK(WHITE) MTJ-032-06A-22	JYRL010LY015
JK703	RCA JACK 1P(RED)WITH SWITCH AV1-09S-2 or	JYRL010RP008
	RCA JACK(RED) MTJ-032-06A-21	JYRL010LY014
JK711	RCA JACK 3P (SW) MSP-213-V2-432 or	JYRL030LY008
	RCA JACK 3P(SW) DA3-19A1N1S001	JYRL030RP014
JK801	HEADPHONE JACK MSJ-035-10A B or	JYSL020LY002
	HEADPHONE JACK DP3-26-7-001	JYSL020RP001
JS571	PCB JUMPER D0.6-P7.5	JW7.5T
JS573	PCB JUMPER D0.6-P7.5	JW7.5T
JS702	PCB JUMPER D0.6-P17.5	JW17.5T
L1	SCREW, B-TIGHT M3X8 BIND HEAD+	GBMB3080
PS691▲	THERMISTOR ZPB58BL7R0F	QNZ258BL7R0F
RCV101	REMOCON RECEIVE UNIT PIC-26042SR-2 or	USESJRSKK032
	REMOCON RECEIVE UNIT PIC-37042SR	USESJRSKK034
RL601▲	POWER RELAY SDT-S-112LMR or	MRNDC12QN014
▲	POWER RELAY RPEF-12-901 or	MRNDC12KB002
▲	RELAY ALKS321	MRNDC12MS013
SA601▲	SURGE ABSORBER PVR-07D471KB or	NVQZ07D471KB
▲	SURGE ABSORBER CNR-07D471K or	NVQZR07D471K
▲	SURGE ABSORBER AVR-S07D471KAAS or	QVQZ0AVRS07D
▲	SURGE ABSORBER JVR-07N471K or	NVQZVR07N471
▲	VARISTOR ENC471D-07A	QVQZ0471D07A
SF11	SAW FILTER SAFHM45M7VAZ00B03	FBB456PMR010
T571▲	FLYBACK TRANSFORMER JF0501-2167 or	LTF00CPXB030
▲	FLYBACK TRANS BW03081	LTF00CP1H001
T572	HORIZONTAL DRAIVE TRANS CSA-LF327A	LTH00CPSA006
T601▲	SWITCHING TRANS KD-03710 or	LTT00CPKT115
▲	SWITCHING TRANS CSA-SW0390A	LTT00CPSA150
TP300	PCB JUMPER D0.6-P12.5	JW12.5T
TP591	PCB JUMPER D0.6-P5.0	JW5.0T
TP592	PCB JUMPER D0.6-P5.0	JW5.0T
TP601	PCB JUMPER D0.6-P20.0	JW20.0T

Ref. No.	Description	Part No.
TU11	TUNER UNIT TEQH9-001A or TUNER B9015AF	UTUNNTUAL032 UTUNNTUSP025
VR561	CARBON P.O.T. 30k Ω B or CARBON P.O.T. 30k Ω B	VRCB303KA011 VRCB303HH014
VR562	CARBON P.O.T. 5k Ω B or CARBON P.O.T. 5k Ω B	VRCB502KA011 VRCB502HH014
VR661▲	CARBON P.O.T. 50k Ω B or ▲ CARBON P.O.T. 50k Ω B	VRCB503KA011 VRCB503HH014
X301	XTAL 3.579545 MHz or XTAL 3.579545MHz(30PPM)	FXD355LLN003 FXD355LCHE01

## CRT CBA

Ref. No.	Description	Part No.
	CRT CBA Consists of the following	-----
<b>CAPACITORS</b>		
C1502	ELECTROLYTIC CAP. 10μF/50V M or ELECTROLYTIC CAP. 10μF/50V M	CE1JMASTL100 CE1JMASDL100
C1510	CERAMIC CAP. B K 1000pF/2KV or CERAMIC CAP. B K 1000pF/2KV or CERAMIC CAP. 1000pF/2KV or CERAMIC CAP. 1000pF/2KV	CCD3DKD0B102 CCD3DKP0B102 CA3D102PAN04 CCD3DKN0B102
C1511	CERAMIC CAP.(AX) B K 270pF/50V	CCA1JKT0B271
C1521	CERAMIC CAP.(AX) B K 270pF/50V	CCA1JKT0B271
C1531	CERAMIC CAP.(AX) B K 270pF/50V	CCA1JKT0B271
<b>CONNECTOR</b>		
CN1501	PIN CONNECTOR 005P-5100	JTEA001TG001
<b>DIODES</b>		
D1511	SWITCHING DIODE 1SS133(T-77) or SWITCHING DIODE 1N4148	QDTZ001SS133 NDTZ001N4148
D1521	SWITCHING DIODE 1SS133(T-77) or SWITCHING DIODE 1N4148	QDTZ001SS133 NDTZ001N4148
D1531	SWITCHING DIODE 1SS133(T-77) or SWITCHING DIODE 1N4148	QDTZ001SS133 NDTZ001N4148
<b>COIL</b>		
L1501	PCB JUMPER D0.6-P5.0	JW5.0T
<b>TRANSISTORS</b>		
Q1511	TRANSISTOR KTC3503Y or TRANSISTOR 2SC3619	NQWY0KTC3503 QQ9Z02SC3619
Q1521	TRANSISTOR KTC3503Y or TRANSISTOR 2SC3619	NQWY0KTC3503 QQ9Z02SC3619
Q1531	TRANSISTOR KTC3503Y or TRANSISTOR 2SC3619	NQWY0KTC3503 QQ9Z02SC3619
<b>RESISTORS</b>		
R1501	CARBON RES. 1/4W J 100 Ω	RCX4JATZ0101
R1502	CHIP RES.(1608) 1/10W J 100 Ω	RRXAJB5Z0101
R1503	CARBON RES. 1/4W J 100 Ω	RCX4JATZ0101
R1510▲	METAL RESISTOR 3W J 10k Ω or ▲ FIXED METAL OXIDE FILM RES. 3W J 10k Ω	RN03103ZU001 RN03103DP005
R1511	CARBON RES. 1/4W J 1.5k Ω	RCX4JATZ0152
R1512	CARBON RES. 1/4W J 1.5k Ω	RCX4JATZ0152
R1515	CARBON RES. 1/4W J 2.7k Ω	RCX4JATZ0272
R1518	CARBON RES. 1/4W J 330 Ω	RCX4JATZ0331
R1519	CHIP RES.(1608) 1/10W J 100 Ω	RRXAJB5Z0101
R1520▲	METAL RESISTOR 3W J 10k Ω or ▲ FIXED METAL OXIDE FILM RES. 3W J 10k Ω	RN03103ZU001 RN03103DP005
R1521	CARBON RES. 1/4W J 1.5k Ω	RCX4JATZ0152
R1522	CARBON RES. 1/4W J 1.5k Ω	RCX4JATZ0152
R1525	CARBON RES. 1/4W J 2.7k Ω	RCX4JATZ0272

Ref. No.	Description	Part No.
R1528	CARBON RES. 1/4W J 330 Ω	RCX4JATZ0331
R1529	CHIP RES.(1608) 1/10W J 100 Ω	RRXAJB5Z0101
R1530▲	METAL RESISTOR 3W J 10k Ω or ▲ FIXED METAL OXIDE FILM RES. 3W J 10k Ω	RN03103ZU001 RN03103DP005
R1531	CARBON RES. 1/4W J 1.5k Ω	RCX4JATZ0152
R1532	CARBON RES. 1/4W J 1.5k Ω	RCX4JATZ0152
R1535	CARBON RES. 1/4W J 2.7k Ω	RCX4JATZ0272
R1538	CARBON RES. 1/4W J 330 Ω	RCX4JATZ0331
R1539	CHIP RES.(1608) 1/10W J 100 Ω	RRXAJB5Z0101
<b>MISCELLANEOUS</b>		
BC1501	BEAD INDUCTORS FBR07HA121TB-00	LLBF00ZTU021
JK1501▲	CRT SOCKET ISHS40ST or ▲ CRT SOCKET HPS0521-012212	JSCC290PK006 JSCC290HD012
JS1511	PCB JUMPER D0.6-P5.0	JW5.0T
JS1521	PCB JUMPER D0.6-P5.0	JW5.0T
JS1531	PCB JUMPER D0.6-P5.0	JW5.0T

